



AMD FirePro™ V7900 SDI

User Guide

© 2011 Advanced Micro Devices Inc. All rights reserved.

The contents of this document are provided in connection with Advanced Micro Devices, Inc. ("AMD") products. AMD makes no representations or warranties with respect to the accuracy or completeness of the contents of this publication and reserves the right to discontinue or make changes to products, specifications, product descriptions, and documentation at any time without notice. No license, whether express, implied, arising by estoppel or otherwise, to any intellectual property rights is granted by this publication. Except as set forth in AMD's Standard Terms and Conditions of Sale, AMD assumes no liability whatsoever, and disclaims any express or implied warranty, relating to its products including, but not limited to, the implied warranty of merchantability, fitness for a particular purpose, or infringement of any intellectual property right. AMD's products are not designed, intended, authorized or warranted for use as components in systems intended for surgical implant into the body, or in other applications intended to support or sustain life, or in any other application in which the failure of AMD's product could create a situation where personal injury, death, or severe property or environmental damage may occur. AMD reserves the right to discontinue or make changes to its products at any time without notice.

Trademarks

AMD, the AMD Arrow logo, ATI, the ATI logo, AMD Athlon, AMD LIVE!, AMD Opteron, AMD Phenom, AMD Sempron, AMD Turion, AMD64, All-in-Wonder, Avivo, Catalyst, CrossFireX, FirePro, FireStream, HyperMemory, OverDrive, PowerPlay, PowerXpress, Radeon, Remote Wonder, Stream, SurroundView, Theater, TV Wonder, The Ultimate Visual Experience, and combinations thereof are trademarks of Advanced Micro Devices, Inc.

HyperTransport is a licensed trademark of the HyperTransport Technology Consortium.

Blu-ray Disc is a licensed trademark of the Blu-ray Disc Association.

HDMI is a licensed trademark of HDMI Licensing, LLC.

DisplayPort is a licensed trademark of Video Electronic Standards Association.

Microsoft, Windows, and Vista are registered trademarks of the Microsoft Corporation in the United States and/or other jurisdictions.

Other names are for informational purposes only and may be trademarks of their respective owners.

Dolby Laboratories, Inc.

Manufactured under license from Dolby Laboratories. Dolby and the double-D symbol are trademarks of Dolby Laboratories.

© 1992-1997 Dolby Laboratories, Inc. All rights reserved.

Rovi Corporation

This device is protected by U.S. patents and other intellectual property rights. The use of Rovi Corporation's copy protection technology in the device must be authorized by Rovi Corporation and is intended for home and other limited pay-per-view uses only, unless otherwise authorized in writing by Rovi Corporation.

Reverse engineering or disassembly is prohibited.

Disclaimer

While every precaution has been taken in the preparation of this document, Advanced Micro Devices, Inc. assumes no liability with respect to the operation or use of AMD hardware, software or other products and documentation described herein, for any act or omission of AMD concerning such products or this documentation, for any interruption of service, loss or interruption of business, loss of anticipatory profits, or for punitive, incidental or consequential damages in connection with the furnishing, performance, or use of the AMD hardware, software, or other products and documentation provided herein. Ensure that you have the latest documentation.

Important Safety Instructions

Note: This product is for use only with compatible UL-listed personal computers that have installation instructions detailing user installation of this class of product.

Read all instructions before beginning installation. All safety and installation instructions should be read before the product is installed or operated.

Retain all instructions. Safety, installation, and operating instructions should be retained for future reference.

Heed all warnings. All warnings regarding the product and its operating instructions should be obeyed.

Use appropriate grounding.

Caution:

For continued protection against the risk of electric shock and fire, install this accessory only in products equipped with a three-wire grounding plug, a plug having a third (grounding) pin. This is a safety feature. Do not remove the grounding pin of a three-pin plug.

Attach product securely. All product-securing screws or fasteners should be completely tightened in order to provide continuous bonding between the product and the PC chassis, as appropriate.

Contents

| | |
|---|-----------|
| Chapter 1 Getting Started | 1 |
| 1.1 System Requirements | 1 |
| 1.2 Performing a Quick Installation | 1 |
| 1.3 Before You Begin Installation | 2 |
| 1.3.1 Recording Serial Numbers | 2 |
| 1.3.2 Uninstalling Previous Drivers in Windows 7 or Windows Vista | 3 |
| 1.3.3 Uninstalling Previous Drivers in Windows XP | 3 |
| | |
| Chapter 2 Product Features | 5 |
| 2.1 Serial Digital Interface (SDI) | 5 |
| 2.2 MultiCard Support | 5 |
| 2.3 Stereographic Glasses | 6 |
| 2.3.1 Quad Buffer Stereo Modes | 7 |
| 2.4 Hydravision | 7 |
| 2.4.1 Hydragrid | 8 |
| 2.4.2 Desktop Manager | 8 |
| 2.4.3 Multi Desktop | 8 |
| 2.5 Load Balancing | 8 |
| 2.6 DisplayPort Audio | 9 |
| | |
| Chapter 3 Hardware Installation | 11 |
| 3.1 Installing a PCI Express Graphics Card | 11 |
| 3.2 Baseplate Connections | 13 |
| 3.2.1 Display connections | 13 |
| 3.2.2 Stereoscopic connection | 13 |
| 3.3 Display Configurations | 14 |
| 3.3.1 Multiple Displays | 15 |
| 3.4 Using Adapters | 16 |
| | |
| Chapter 4 Software Installation | 19 |
| 4.1 AMD Drivers and Software | 19 |
| 4.2 Installing AMD Drivers and Software in Windows Vista or Windows 7 | 19 |
| 4.3 Installing AMD Drivers and Software in Windows XP | 20 |
| 4.4 AMD Automatic Application Detection and Configuration | 21 |
| 4.5 Enabling SDI | 22 |

| | |
|--|-----------|
| Chapter 5 Using the Control Center Software | 23 |
| 5.1 Control Center Overview..... | 23 |
| 5.2 Starting the Control Center Software..... | 23 |
| 5.3 Viewing the Control Center Help..... | 24 |
| | |
| Chapter 6 AMD CrossFire Pro Technology | 25 |
| 6.1 AMD CrossFire Pro Overview..... | 25 |
| 6.2 Installing AMD CrossFire Pro Graphics Cards..... | 25 |
| 6.3 Enabling AMD CrossFire Pro..... | 28 |
| | |
| Chapter 7 Reference | 29 |
| 7.1 Workstation Card Troubleshooting..... | 29 |
| 7.1.1 Computer does not boot up properly..... | 29 |
| 7.1.2 There is no display..... | 29 |
| 7.1.3 There are screen defects..... | 30 |
| 7.1.4 The screen image is off-center or there are odd colors..... | 30 |
| 7.1.5 The operating system warns that the graphics card isn't properly configured..... | 30 |
| 7.1.6 There are bus address or interrupt conflicts..... | 31 |
| 7.2 Workstation Customer Care..... | 31 |
| 7.2.1 Web..... | 31 |
| 7.2.2 E-mail..... | 31 |
| 7.2.3 Telephone..... | 32 |
| 7.2.4 Surface Mail..... | 33 |
| 7.2.5 Disclaimer..... | 33 |
| 7.3 Workstation Warranty Service..... | 33 |
| 7.3.1 Shipping..... | 33 |
| 7.3.2 Limitations..... | 34 |
| 7.4 Additional Accessories..... | 34 |
| 7.5 International Compliance Information..... | 34 |
| 7.5.1 FCC Compliance Information (USA)..... | 35 |
| 7.5.2 Industry Canada Compliance Statement (Canada)..... | 36 |
| 7.5.3 CE Compliance Information (European Union)..... | 36 |
| 7.5.4 Electrical Safety..... | 37 |
| 7.5.5 VCCI ITE Compliance Information (Japan)..... | 37 |
| 7.5.6 KC Certification Information (Korea)..... | 38 |
| 7.5.7 BSMI Certification Information (Taiwan)..... | 39 |
| 7.5.8 C-Tick (Australia and New Zealand)..... | 40 |

| | |
|--|-----------|
| 7.5.9 Product Environmental Compliance..... | 40 |
| 7.5.10 Waste Electrical and Electronic Equipment (WEEE) Directive Compliance (European Union)..... | 40 |
| Appendix A Glossary - Workstation Products | 41 |

Chapter 1

Getting Started

Before you begin installing your new AMD FirePro V7900 SDI graphics card, please make sure you have the proper system requirements and have completed the required preinstallation tasks as outlined in this chapter.

System Requirements

Table 1–1 AMD FirePro V7900 SDI Minimum System Requirements

| | |
|------------------|--|
| Hardware | <p>All of the following:</p> <ul style="list-style-type: none">• AMD Athlon™ or Intel Pentium® 4 CPU.• 512 MB RAM.• Motherboard with available ×16 lane PCI Express® connection slot and correct chipset driver.• Certified power supplies are strongly recommended. For a list of certified power supplies, see support.amd.com/us/certified/power-supplies. <p>For SDI functionality:</p> <ul style="list-style-type: none">• A certified SDI I/O card. For a list of AMD-certified SDI I/O cards, see www.amd.com/sdi-tech. |
| Operating System | <p>Any of the following:</p> <ul style="list-style-type: none">• Windows® 7 (32- or 64-bit).• Windows Vista® (32- or 64-bit).• Windows® XP Home or Pro with Service Pack 1 or higher (32- or 64-bit).• Linux® (32- or 64-bit). |
| Monitor | <p>Any of the following:</p> <ul style="list-style-type: none">• High-resolution multisync or multi-frequency monitor, or any VGA monitor.• DisplayPort monitor.• Digital flat-panel (DFP) display or digital CRT display.• HDMI™ display. |

Performing a Quick Installation

Experienced users and system administrators can follow these brief instructions for installing this AMD FirePro product.

Other users should refer to the detailed installation instructions, starting with [Chapter 3 Hardware Installation](#).

1. Uninstall the drivers and software for any installed graphics card(s).

Note: If you are using a motherboard containing an on-board graphics solution and do not intend to use it as part of a multiple monitor display, disable it.

2. Shut down and disconnect your computer system.
3. Remove any installed graphics card(s).
4. Install your new AMD FirePro graphics card.
5. Reassemble and connect your computer system.
6. Download and install the AMD FirePro drivers and configuration software from the AMD website.

Before You Begin Installation

Once you have determined that your system meets the minimum requirements, please perform the following tasks before installing your AMD FirePro V7900 SDI workstation graphics card.

Recording Serial Numbers

The serial number and 102 part number on the graphics card are required for product registration. They are located on a sticker on the back of the graphics card and are shown in boldface and underlined in the illustration below.

Record these numbers in the space provided below and retain for future use.

1. Remove the graphics card from packing.
2. Locate the white label on the back of the graphics card.
3. Record the serial number and 102 part number.

Figure 1–1 Typical Serial Number and 102 Part Number Arrangement



| | |
|---|-----------------------|
| 1 | Serial number (S/N) |
| 2 | 102 part number (P/N) |

Uninstalling Previous Drivers in Windows 7 or Windows Vista

Follow these steps to uninstall the existing graphics card driver in Windows 7 or Windows Vista in preparation for installation of a new card.

1. With the current graphics card still in the computer, close all open applications.
2. Click **Start** ► **Control Panel**. Double-click **Programs and Features** and then select the graphics card driver from the list of software programs.
3. Double-click **Hardware and Sound** and then double-click **Device Manager**.
4. Expand **Display Adapter** and then right-click the driver for the graphics card you are replacing.
5. In the shortcut menu that appears, click **Uninstall**.
The driver for the old graphics card is uninstalled.
6. Turn off the system.

Uninstalling Previous Drivers in Windows XP

Follow these steps to uninstall the existing graphics card driver in Windows XP in preparation for installation of a new card.

1. With the current graphics card still in the computer, close all open applications.
2. On the Windows taskbar, click **Start** ► **Control Panel** and then double-click **Add or Remove Programs**.
3. Select the current graphics card driver and then click **Add/Remove**.
Use the wizard that appears to remove the current display drivers.
4. Turn off the system after the driver has been removed.

Note: If the previously installed graphics card has any additional software installed, this software may also need to be removed before restarting the computer. For example, DVD Player or Multimedia applications.

Chapter 2

Product Features

This chapter contains information on special features associated with the AMD FirePro V7900 SDI.

Serial Digital Interface (SDI)

Serial Digital Interface (SDI) consists of a series of video standards used in the professional video industry to provide broadcast-grade video. SDI is standardized by the Society of Motion Picture and Television Engineers (SMPTE) and is used to transmit uncompressed digital signals with or without embedded audio within television broadcast studios.

SD-SDI, the standard used for standard-definition video, provides data rates up to 360 Mbits/s. HD-SDI, the standard used for high-definition video, provides a nominal data rate of 1.5 Gbits/s. For greater high-definition needs, the Dual-Link HD-SDI and 3G-SDI standards also exist to provide even faster data rates.

Due to their high data rates, SDI interfaces are intended only for short distance transmission and professional use.

Note: To use SDI functionality of your AMD FirePro V7900 SDI graphics card, a certified SDI I/O card is required. For a list of certified SDI I/O cards, see www.amd.com/sdi-tech.

Note: SDI is not enabled by default. To enable it, see [Enabling SDI](#).

MultiCard Support

MultiCard Support is a feature that enables you to fully use the power of your AMD FirePro graphics cards when more than one card is installed in a single system with multiple displays.

With MultiCard functionality, each OpenGL graphics application automatically uses the graphics engine of whichever GPU is associated with the display on which the application is initially launched. Users who wish to run two OpenGL graphics applications can take full advantage of their two GPUs by ensuring that the two applications are launched on displays connected to different graphics cards.

For example, in a configuration comprised of four displays attached to two graphics cards, you can obtain optimal performance for two OpenGL applications by launching the first application on a display attached to graphics card #1 and launching the second application on a display attached to graphics card #2.

Note: If a user launches an OpenGL application on a display attached to graphics card #1 and then moves the application window to a display attached to graphics card #2, the application will continue to use the capabilities of the original GPU (card #1 in this case) and not the capabilities of card #2; the image is rendered via the GPU on card #1 and then copied over to the second card's display(s). This copy process is less efficient than rendering on a display connected to the same GPU and results in a performance penalty.

In order to make it easier for users to manage which OpenGL applications launch on which display, the AMD FirePro card comes with HydraVision™ APS (Application Position and Size) as a standard part of the driver installation package on Windows® 7, Windows Vista®, and Windows® XP platforms. HydraVision APS provides the capability to remember which display (and therefore which graphics card) an application was last located on (as well as the application's exact position and size) and to open there on subsequent invocations. The OpenGL driver works with HydraVision APS to allocate 3D resources in an optimal manner.

With the HydraVision APS package installed, a user's second OpenGL application can be fully accelerated via the second graphics card by ensuring that the second OpenGL application is launched on the second graphics card, as follows:

1. Launch the second OpenGL application.
2. Move it to a display attached to the second card.
3. Exit the application.
4. Relaunch the same application.

By taking these simple steps, the second OpenGL application will be automatically launched on the second card and thereby use the full power of the second graphics card.

When running three or more OpenGL applications simultaneously, the same principles apply. Launch the application on the display attached to the graphics card that you want the application to use.

Note: The following are known limitations:

1. Once HydraVision APS has been installed, users other than the original user who installed HydraVision APS will not be able to install an older version of HydraVision on Windows Vista.
2. HydraVision APS is unable to track and preserve the screen position and size of WildFire 2 Pro Engineer.

Stereographic Glasses

Your AMD FirePro™ graphics card can enable quad-buffer stereo display, which is used with special glasses to display images in 3D.

Quad buffering allows for smooth stereoscopic viewing under the following conditions:

- The **Enable Quad Stereo** option has been selected in the Control Center application through the **Workstation** aspect.

Note: You must reboot your system after enabling quad buffering for the first time.

- An appropriate quad buffer stereo mode has been selected in the Control Center application through the **Workstation** aspect.

Note: Refresh rates below 120 Hz will display noticeable “shutter” interference. Because many LCD displays cannot achieve a sufficient refresh rate, CRT displays are usually preferable.

Quad Buffer Stereo Modes

The following modes are available:

- **Active Sync (Sync Signal Enabled):** Select this option for display devices connected to the active synchronization connector on the graphics card. The setting is selected by default.
- **Auto-Stereo (Vertical Interleaved):** Select this option for auto-stereo display devices that support vertically interleaved stereo image pairs.
- **Auto-Stereo (Horizontal Interleaved):** Select this option for auto-stereo display devices that support horizontally interleaved stereo image pairs.
- **Passive (Dual Head):** Select this option for passive stereo display devices that support dual video input.
- **Passive with Horizontal Invert (Dual Head):** Select this option for passive stereo display devices that support horizontally inverted stereo image pairs.
- **Passive with Vertical Invert (Dual Head):** Select this option for passive stereo display devices that support vertically inverted stereo image pairs.

The vertical and horizontal interleaved stereo modes are available only for graphics cards with auto-stereo support via a stereo 3D output.

Passive stereo modes can be enabled in Cloned Desktop mode only. When a passive stereo mode is selected, your system will automatically reboot and work in clone mode. Extended Desktop mode is not compatible with passive stereo modes.

Hydravision

The **Hydravision** tab on the **Workstation** aspect of the Control Center application provides a number of display options.

Hydragrid

You can use HydraGrid to apply invisible grid layouts to desktops in single- and multi-display environments. When HydraGrid is enabled, application windows can be attached to individual cells in a grid, restricting their display to a specific area on a desktop.

HydraGrid preserves layouts on a per-user basis and is designed for window management across large, multiple, or virtual desktops.

Note: HydraGrid does not affect full-screen and non-resizable applications.

Desktop Manager

Desktop Manager contains options for configuring the behavior of application windows and dialogs in a multi-display environment. With Desktop Manager you can:

- Preserve and restore application window position and size.
- Maximize application windows across multiple displays.
- Reposition application dialog boxes.

Tip: To access the full capabilities of Desktop Manager, ensure you are working in a multi-display environment, as not all features are available in a single-display environment.

Multi Desktop

Using the Multi Desktop component of HydraVision, you can create and manage up to nine virtual desktops, each with their own display settings and background image. One desktop can be made visible at a time, while others can run in the background.

Using Multi Desktop, you can also:

- Switch between desktops using a mouse click or hot key.
- Run applications on a particular desktop or all desktops.
- Move running applications between desktops.
- Save, restore, and delete desktop profiles.

Load Balancing

GPU load balancing is a feature that allows OpenGL 3D rendering tasks to be distributed among multiple workstation graphics processors in order to provide performance gains for multi-context and multi-simultaneous applications.

This feature is available only if your system contains multiple graphics processor that are capable of load balancing. Graphics processors working in AMD CrossFireX™ mode count as a single graphics processor.

Note: This feature is available only on systems running Windows XP.

To set up OpenGL load balancing, consult the Control Center application help section.

DisplayPort Audio

DisplayPort audio requires up-to-date graphics drivers, and the display device must support DisplayPort audio.

As with HDMI™, DisplayPort audio is enabled through Windows. For more information, consult your Windows documentation.

Chapter 3

Hardware Installation

This chapter details how to install your AMD FirePro V7900 SDI card in your system.

Note: AMD recommends that you install/upgrade all AMD FirePro hardware products in your system before you install/upgrade your drivers and the AMD Accelerated Parallel Processing (APP) Software Development Kit (SDK).

Installing a PCI Express Graphics Card

Please read all installation instructions completely before you begin.

If your computer has on-board graphics, you may need to disable it through the BIOS configuration. For more information, see your motherboard documentation.

Note: Always handle a graphics card with care when adding or removing it from your system.

- Never twist or bend your card.
 - Avoid interference from the card's fan housing with mechanical hinges or clips inside your system's chassis.
 - Make sure that the PCIe® card slot-locking mechanism on the motherboard is unlocked or open before inserting or removing a card. Please consult your motherboard manual for instructions, if necessary.
1. Turn off your computer, monitor(s), and other peripheral devices.
 2. Unplug the computer's power cord, and then disconnect all cables from the back of the computer.

Caution:

Wait approximately 20 seconds after unplugging the power cord before disconnecting a peripheral cable or removing a component from the motherboard to avoid possible damage to the motherboard.

3. Remove the cover to your computer's case.

Note: If necessary, consult your computer's manual for help in removing the cover.

Caution:

Static electricity can seriously damage computer components. Discharge your body's static electricity by touching the power supply or the metal

surface of the computer chassis before you touch any components inside your computer's case to avoid damaging them.

4. Unscrew or unfasten and remove any existing graphics card from your computer, if necessary.

Caution:

Make sure the PCIe card slot-locking mechanism is unlocked or open before trying to remove a graphics card. Failure to do so may damage the card and/or the motherboard. This locking mechanism may be hidden from view by a card's fansink.

Figure 3–1 Example PCIe Card Slot-locking Mechanism

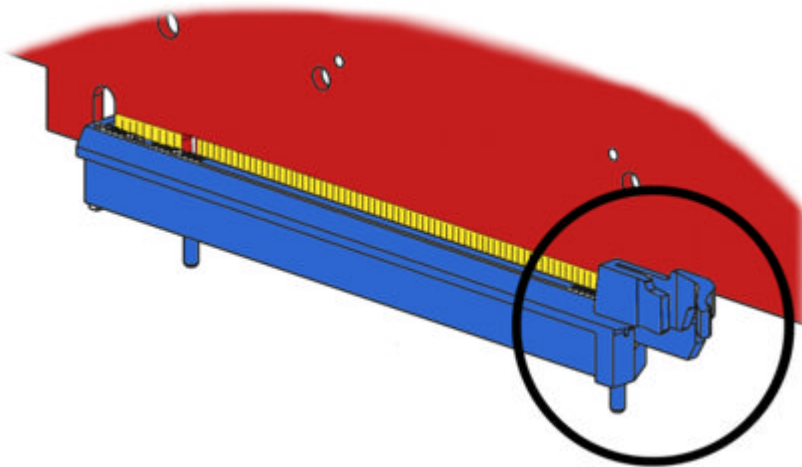

5. Locate the appropriate slot and, if necessary, remove the metal back-plate cover. Make sure all internal cables are clear of the slot.
6. Align your AMD FirePro graphics card with the PCIe slot and press it in firmly until the card is fully seated. You may need to hold open the PCIe card slot-locking mechanism with your finger when you seat the card.
7. Screw in or fasten the graphics card securely.
8. If your card requires supplementary power and must be connected directly to the power supply, locate the appropriate power connector cable (or cables) from the power supply and connect it (or them) to the graphics card's supplementary power connector(s), which are usually located in the upper corner of the card.

Note: Before installing a card that requires a supplementary power connection, make sure your existing power supply has such a connection available.
9. Make sure no internal cables are interfering with components inside the computer (for example, a cooling fan) and replace the computer cover.
10. Reconnect any cables that were disconnected during installation and plug in the computer's power cord.
11. Turn on the monitor, and then your computer.

If you have properly installed your graphics card, operating system messages will appear and the boot procedure will proceed.

Your monitor will be running in a basic (VGA) video mode. Higher refresh rates are not available at this stage of the installation. Once you have installed the AMD FirePro drivers and software, you can use the Windows® **Display Properties** dialog to adjust your video settings and configure multiple monitors.

Proceed to install the software and drivers for your AMD FirePro graphics card.

Baseplate Connections

Display connections

The following figure shows the display connections on your graphics card.

Note: Baseplate may not appear exactly as depicted.

Figure 3–2 AMD FirePro V7900 SDI Display Connections

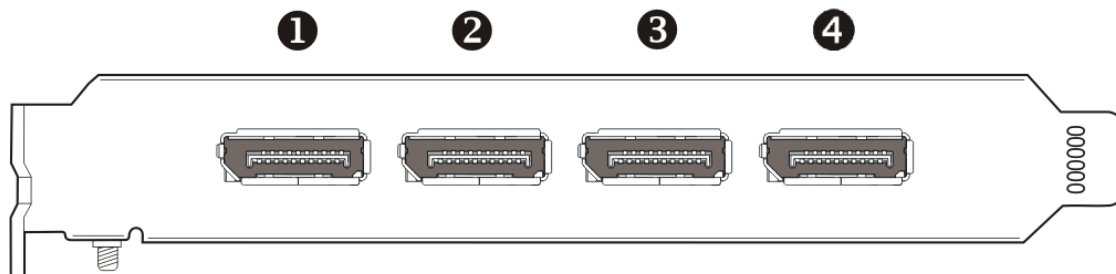

| | |
|---|------------------------|
| 1 | DisplayPort Connection |
| 2 | DisplayPort Connection |
| 3 | DisplayPort Connection |
| 4 | DisplayPort Connection |

Stereoscopic connection

The following figure shows the stereoscopic port that connects your AMD FirePro V7900 SDI graphics card to stereographic glasses. The bracket can be attached if needed, or left off so that the graphics card covers only one PCI slot in the computer's case.

Note: Baseplate may not appear exactly as depicted.

Figure 3–3 AMD FirePro V7900 SDI Stereoscopic Connection

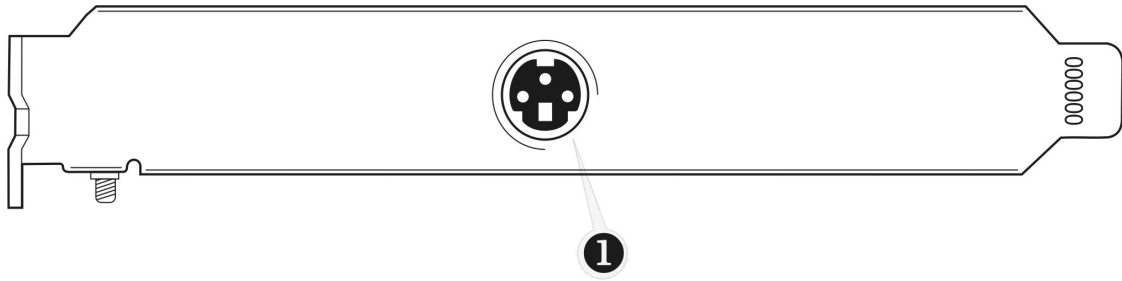

| | |
|---|-------------------------|
| 1 | Stereoscopic Connection |
|---|-------------------------|

The following figure shows where the cable from the stereoscopic bracket connects to your AMD FirePro V7900 SDI graphics card.

Figure 3–4 Stereoscopic cable connection

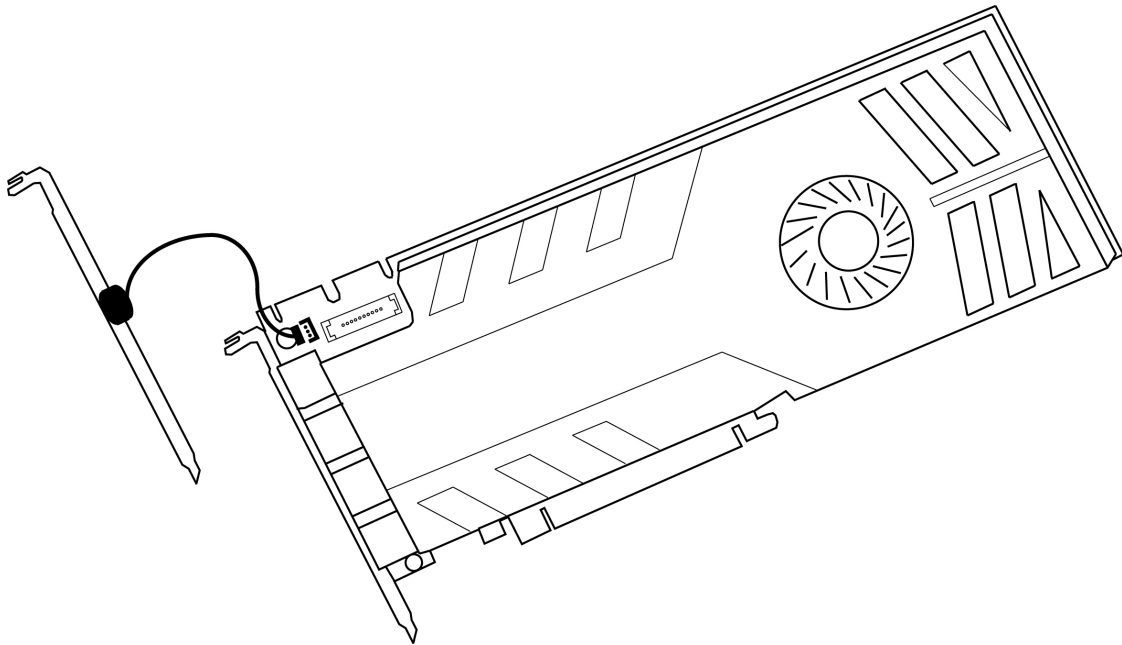

Display Configurations

The following table lists the different ways you can connect displays to your card:

Table 3–1 Display Connection Options

| Display | Connection Options |
|----------------------------------|---|
| DisplayPort display | DisplayPort connection |
| DFP (digital flat-panel) display | DisplayPort connection with DisplayPort-to-DVI adapter (single- or dual-link) |
| HDMI™ display | DisplayPort connection with DisplayPort-to-HDMI adapter |
| CRT (cathode ray tube) display | DisplayPort connection with DisplayPort-to-VGA adapter |

Note: Your AMD FirePro V7900 SDI comes with 4 DisplayPort-to-DVI adapters (**single-link, active**).

Once displays are connected to the graphics card, you can control how they are currently configured as well as how desktops appear on the displays using the Control Center software application. Common configuration tasks include:

- Adding and removing displays
- Rotating displays
- Setting the main (primary) display
- Duplicating and extending desktops
- Arranging desktops

For more information, see [Chapter 5 Using the Control Center Software](#).

Multiple Displays

AMD FirePro V7900 SDI graphics cards with four DisplayPort connections provide display functionality for up to four displays in Windows® 7, Windows Vista®, or Linux®. The following are the maximum possible configurations (using adapters where necessary):

- 4 × DisplayPort
- 4 × dual-link DVI
- 4 × VGA
- 4 × single-link DVI

Note: 4 × active single-link DVI adaptors are included with your graphics card.

- 2 × HDMI

Adapters not included with your AMD FirePro V7900 SDI can be purchased directly from AMD's Web site or through your local AMD resellers.

Different types of displays can be combined within the following parameters:

- Your AMD FirePro V7900 SDI has two clocks and four DisplayPort connections.
- Two active displays (DisplayPort, active single-link DVI, dual-link DVI, and VGA) can share a clock, while passive displays (passive single-link DVI and HDMI) require a separate clock per device.

The true limit on multiple displays is four active displays, two active and two passive displays, or two passive displays.

The following table shows some examples of multiple display configurations for the AMD FirePro V7900 SDI graphics card with four connections. (A) indicates an active adapter is used and (P) indicates a passive adapter is used. Display abbreviations are DP = DisplayPort, sDVI = single-link DVI, and dDVI = dual-link DVI.

Table 3–2 Sample Display Configurations

| Sample Display Configuration | DP Connector | DP Connector | DP Connector | DP Connector | Total Output |
|------------------------------|----------------|----------------|----------------|---------------|--------------|
| DP-DP-DP-DP | Native | Native | Native | Native | 4 |
| DP-DP-VGA-dDVI | Native | Native | DP to VGA (A) | DP to DVI (A) | 4 |
| dDVI-dDVI-dDVI-dDVI | DP to DVI (A) | DP to DVI (A) | DP to DVI (A) | DP to DVI (A) | 4 |
| VGA-VGA-VGA-VGA | DP to VGA (A) | DP to VGA (A) | DP to VGA (A) | DP to VGA (A) | 4 |
| DP-DP-DP-VGA | Native | Native | Native | DP to VGA (A) | 4 |
| DP-DP-DP-dDVI | Native | Native | Native | DP to DVI (A) | 4 |
| DP-DP-HDMI | Native | Native | DP to HDMI (P) | No connection | 3 |
| HDMI-HDMI | DP to HDMI (P) | DP to HDMI (P) | No connection | No connection | 2 |
| sDVI-dDVI-dDVI | DP to DVI (P) | DP to DVI (A) | DP to DVI (A) | No connection | 3 |

Additional configuration information can be found at:

<http://sites.amd.com/us/business/products/pro-graphics/eyefinity/Pages/eyefinity-for-professionals.aspx>

A list of compatible adapters/dongles for AMD FirePro products can be found at:

<http://support.amd.com/us/eyefinity/Pages/eyefinity-dongles.aspx>

Important: Windows® XP supports a maximum of two displays of any type; for four-display functionality, you must use Windows 7, Windows Vista, or Linux (Ubuntu, openSUSE, or Red Hat Enterprise Linux 6 with the following packages installed: X.Org RandR 1.2 and SUSE Linux Enterprise Server 11 or SUSE Linux Enterprise Desktop 11).

Using Adapters

Your AMD FirePro graphics card includes adapters to enable you to attach display types other than those included on the baseplate or cables.

Use the following procedure to attach a display using an adapter.

1. Turn off your computer and monitor.
2. Plug the adapter into the connection from your AMD FirePro card and tighten the thumbscrews (if there are any).
3. Connect your display's cable to the adapter and tighten the thumbscrews (if there are any).

4. Turn on your monitor first, then your computer.

Use the Control Center application to configure the new monitor, should you need to do so.

Chapter 4

Software Installation

This chapter describes the installation of the software and drivers associated with your AMD FirePro product.

AMD Drivers and Software

Drivers are small but important programs that enable an operating system to communicate with a piece of hardware, such as a graphics card.

When you install a new graphics card, you must also install the driver and configuration software the card requires to function properly.

You also need to install (or reinstall) your AMD FirePro drivers when you have reinstalled or upgraded your operating system or when you download updated drivers from AMD's Web site: support.amd.com/us/gpudownload/Pages/index.aspx.

Note: When reinstalling drivers, always uninstall any previous drivers that are on your system, even if they are for the same graphics card. Always start "fresh."

Installing AMD Drivers and Software in Windows Vista or Windows 7

In order to install the drivers and software necessary for your AMD FirePro V7900 SDI graphics card to function properly, the following must be true:

- Your AMD FirePro V7900 SDI graphics card must be physically installed in your computer.
 - Your operating system must be installed and operational.
 - You must log in as a user with administrator rights.
 - You must have downloaded the software installation package from www.amd.com/sdi-tech to a folder on your hard drive.
1. Turn on your monitor and then turn on your computer. Wait for your operating system to boot up. You may receive a warning that the graphics driver failed to install. Close this dialog.
 2. Run the Setup utility from the downloaded software installation package.
 3. In the **Software Install** dialog, click **Install**.

4. Click **Next**.

The installation wizard will start.

5. Follow the wizard's instructions to complete the installation:

➤ Select **Express** to install typical drivers and software.

➤ Select **Custom** to choose individual software components for installation.

Note: The Custom installation option is recommended for advanced users only.

6. Click **Yes** to accept the license agreement.

7. When the installation is complete, select **View Log** to review installation details. Click **Finish** when done; reboot your computer when prompted.

Your computer will reboot.

Proceed to configure your video settings and connect additional monitors, if necessary.

Installing AMD Drivers and Software in Windows XP

In order to install the drivers and software necessary for your AMD FirePro V7900 SDI card to function properly, the following must be true:

- Your AMD FirePro V7900 SDI card must be physically installed in your computer.
- Your operating system must be installed and operational; you must have at least Windows® XP Service Pack 1 installed.
- You must log in as a user with administrator rights.
- You must have downloaded the software installation package from www.amd.com/sdi-tech to a folder on your hard drive.

1. Turn on your monitor and then turn on your computer. Wait for your operating system to boot up. When the **Found New Hardware** dialog appears, click **Cancel**. If the **System Settings Change** dialog asks if you want to restart your computer, click **No**.

2. Run the Setup utility from the downloaded software installation package.

3. In the **Software Install** dialog, click **Install**.

4. Click **Next**.

5. Click **Yes** to accept the license agreement.

The installation wizard will start.

6. Follow the wizard's on-screen instructions to complete the installation:

➤ Select **Express** to install typical drivers and software.

➤ Select **Custom** to choose individual software components for installation.

Note: The Custom installation option is recommended for advanced users only.

7. When the setup complete message appears, select **Yes, I want to restart my computer now** and click **Finish**.
8. After the system reboots, the **Found New Hardware** dialog may display the **Digital Signature Not Found** message. Click **Yes** or **Continue** to complete the driver installation.

Proceed to configure your video settings and connect additional monitors, if necessary.

AMD Automatic Application Detection and Configuration

AMD FirePro drivers offer automatic application detection and configuration, which enables the graphics driver to automatically detect an application when it starts and configure the graphics driver settings for optimal performance.

This detection feature works with multiple open applications. As a user moves among multiple applications, the graphics settings are always automatically configured for maximum performance for the particular application currently running.

At publication, the automatic application detection and configuration feature supports the following applications:

| | |
|--------------------------|--------------------------|
| • Abaqus | • ICEM Surf |
| • Adobe After Effects | • IronCAD |
| • Altair HyperWorks | • LightWave 3D |
| • ArcGIS | • MicroStation |
| • Autodesk 3ds Max | • Maya |
| • Autodesk AliasStudio | • modo |
| • Autodesk Inventor | • MCS.Patran |
| • Autodesk AutoCAD | • NX I-deas |
| • Autodesk Revit | • Opticore Studio Studio |
| • Autodesk VIZ | • Petrel |
| • Autodesk Motionbuilder | • Poser |
| • Axio Vision | • Pro/ENGINEER Wildfire |
| • CATIA | • SOFTIMAGE XSI |
| • CoCreate Modeling | • SolidWorks |
| • Discovery Studio | • Solid Edge |
| • Fluent | • Tebis |
| • Freeform Modeling Plus | • UGS NX |
| • Google Earth | • Vitrea |
| • Houdini | |

Note: The trademarks and trade names in the preceding list refer to either the entities claiming the marks and names or their products. Advanced Micro Devices, Inc. disclaims any proprietary interest in trademarks and trade names other than its own.

If a user starts an application that is not currently supported, the default profile setting will be used for that application.

Enabling SDI

SDI functionality is not enabled by default on your AMD FirePro V7900 SDI. It must be enabled in the Catalyst™ Control Center software application. Once the AMD drivers and software have been downloaded and installed (see the installation instructions in [Chapter 4 Software Installation](#)), complete the following steps to enable SDI functionality.

1. Launch the Catalyst Control Center.
2. Navigate to the **AMD FirePro** ▶ **Serial Digital Interface** page.
3. Check the **Enable Serial Digital Interface** checkbox.
4. Use the slider to select the size of the DirectGMA aperture exposed by the GPU.

Chapter 5

Using the Control Center Software

Control Center Overview

The Control Center software application contains settings for configuring and fine-tuning your AMD product. Use it to manage desktops and displays, optimize your graphics processor for enhanced 3D application and video quality, and configure your CPU for improved power savings or system performance. You can also use the performance tools in the application to monitor and manage clock speed and memory use for your graphics card to ensure that your AMD product is configured and running as efficiently as possible.

The application provides a Standard View for guided configuration and an Advanced View for quick and easy access to all available features and settings. It also provides a search feature for finding specific pages, as well as the ability to bookmark pages by pinning them within the application.

The following is a list of common configuration tasks that can be completed using the application:

- Adding and removing displays
- Rotating displays
- Setting the main (primary) display
- Duplicating and extending desktops
- Arranging desktops
- Enabling and disabling 3D application and video settings

More information on the application and its available features are provided through the comprehensive Control Center help system. For information on accessing the help system, see [Viewing the Control Center Help](#).

Note: Feature availability varies between AMD products and operating systems.

Starting the Control Center Software

You can use any of the following methods to start the Control Center software application.

Table 5–1 Control Center Access Routes

| Access Route | Instructions |
|---------------------------|--|
| Windows® Desktop | <ol style="list-style-type: none">1. Right-click anywhere on the desktop.2. From the shortcut menu that appears, click the Control Center option. |
| Windows Start Menu | <ol style="list-style-type: none">1. Click Start on the Windows task bar.2. Click All Programs followed by the Control Center option. |
| Windows Notification Area | <ol style="list-style-type: none">1. Right-click the Control Center icon in the Windows Notification Area.2. From the shortcut menu, click the Control Center option. |
| Desktop Shortcut | If you chose to create a desktop shortcut to the Control Center application during the driver installation, double-click the shortcut. |

Viewing the Control Center Help

The help system that is available with the Control Center software application provides detailed usage information and tips for configuring your AMD product. The help system also provides conceptual information on the technologies that are available for your product.

Use the following steps to access the help system.

1. Open the Control Center application.
2. Choose one of the following options:
 - Set the mouse focus to the application window (by clicking the window) and press F1 on your keyboard.
 - Click the Help button (shown as a question mark) located in the titlebar of each page within the application.
 - Right-click the Control Center icon in the Windows taskbar notification area (system tray), and click **Help**.

The help system opens to provide context-sensitive help for the current page or general usage information.

Chapter 6

AMD CrossFire™ Pro Technology

Note: These features are only available for AMD FirePro V7900 SDI graphics cards with AMD CrossFire™ Pro connections.

AMD CrossFire™ Pro Overview

AMD CrossFire Pro is a multi-GPU (graphics processing unit) high performance graphics platform. It enables two graphics processors installed in a single computer to work together to improve system performance.

Once your graphics cards have been installed, you can enable and configure AMD CrossFire Pro support using the Control Center software application.

Installing AMD CrossFire™ Pro Graphics Cards

These instructions assume that a PCIe® graphics card has already been successfully installed in the secondary slot (slot one), and that the primary slot (slot zero) is empty.

For an up-to-date listing of AMD CrossFire Pro certified motherboards and power supplies, see <http://support.amd.com/us/certified/Pages/certified-components.aspx>

1. Make sure the computer, monitor, and other peripheral devices are off.
2. Unplug the computer power cord and disconnect the monitor cable from the back panel of the computer.

Caution:

To avoid possible damage to the motherboard, wait approximately 20 seconds after unplugging the power cord before disconnecting a peripheral or removing a component from the motherboard.

3. Remove the computer cover.
If necessary, consult the computer manual for help removing the cover.

Caution:

Remember to discharge your body's static electricity by touching the power supply case or the metal surface of the computer chassis.

4. Locate the primary PCIe slot on the motherboard. If necessary, remove the corresponding back panel cover.

5. Align the new workstation card in the primary PCIe slot next to the existing graphics card and press firmly until the card is fully seated.

Figure 6–1 AMD FirePro™ Card Installation

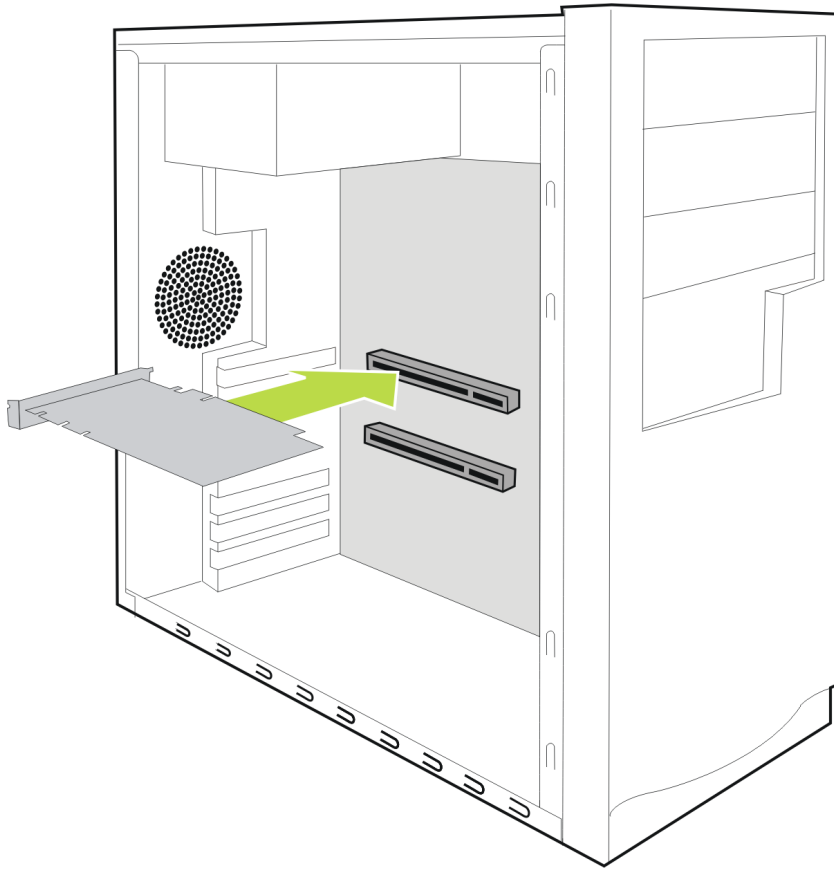

Note: You may need to hold open the PCIe card slot-locking mechanism with your finger when you seat the card.

6. Fasten the workstation card securely to the back panel.
7. Connect external power to the workstation card from the systems power supply, if necessary.

8. Connect the two AMD FirePro™ workstation cards using the AMD CrossFire Pro bridge interconnect.

Figure 6–2 AMD CrossFire™ Pro Interconnect Installation

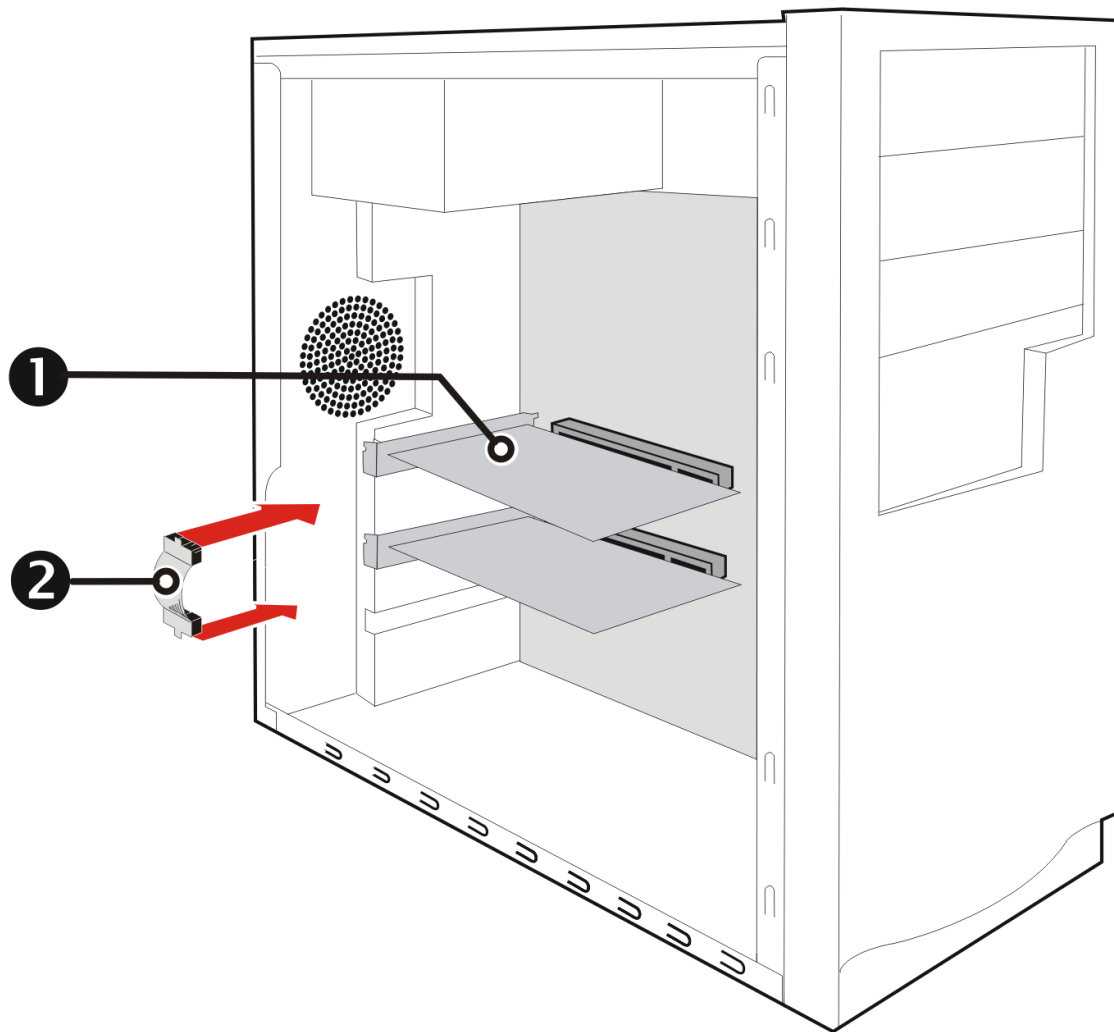

| | |
|---|----------------------------------|
| 1 | Newly installed AMD FirePro card |
| 2 | AMD CrossFire Pro Interconnect |

9. Make sure that no cables are interfering with anything inside the computer (for example, a cooling fan) and then replace the computer cover.
10. Reconnect any cables you have disconnected and plug in the computer power cord.
11. Turn on the monitor and then the computer.

Enabling AMD CrossFire™ Pro

Note: The CrossFire option will not appear unless two workstation cards are installed in the system and connected using an AMD CrossFire Pro interconnect.

1. Based on the navigation layout of the Control Center application window, do one of the following:
 - Navigation menu—On the **Graphics** menu, click **CrossFireX™**.
 - Navigation tree—From the tree in the **Graphics Settings** tab, click **CrossFireX™**.
2. Click **Configure**.
3. From the **Graphics Adapter** list, select the graphics card to act as the display GPU.
4. Select **Enable CrossFireX™**.

Note: The **Choose from the following Rendered GPU combinations** drop-down list automatically populates with all available render GPUs based on the selected display GPU. The list displays only GPUs that can be enabled for AMD CrossFireX. Other combinations are not listed here but may be listed on the **CrossFire™ ▶ Diagnostics** page.

5. From the list, select the appropriate combination.

Note: If the selected combination is not the most optimal choice for your system, a message appears at the bottom of the page notifying you of this.

6. Click **Apply**.

In some configurations, when AMD CrossFire is enabled, GPU Accelerated Physics is automatically disabled for all cards in the configuration as are all displays except the one used by AMD CrossFire.

Chapter 7

Reference

This chapter provides notices, troubleshooting tips, and customer care, warranty, and standards-compliance information.

Workstation Card Troubleshooting

The following troubleshooting tips may help if you experience problems.

More troubleshooting information can be found on the AMD Web site. Please visit ati.amd.com and select Customer Care.

Computer does not boot up properly.

Verify that the installation instructions were properly followed. In particular, if external power is required, make sure that the external power cable (or cables) is properly connected.

Check that the card is properly installed in your system and connected to your monitor.

If you have problems during start-up, restart your computer in Safe Mode. While starting Windows® XP, press and hold **F8** until you see the **Advanced Options Menu**. Use the arrow keys to select **Safe Mode**, and press **Enter**.

Check the system configuration utility of your operating system for the interrupt assignments.

Contact AMD's Customer Care or your local technical support.

There is no display.

Make sure the card is seated properly in its slot. If external power is required, make sure that the external power cable (or cables) is properly connected to the card.

Make sure that the monitor cable is securely fastened to the card.

Make sure that the monitor and computer are plugged in and receiving power.

If necessary, disable any built-in graphics capabilities on your motherboard. For more information, consult your computer's manual or manufacturer.

Note: Some manufacturers do not allow the built-in graphics to be disabled or to become the secondary display.

Make sure that you selected the appropriate monitor when you installed your enhanced driver.

Make sure that the display resolution and refresh rate settings you have selected are supported by the monitor you have connected.

There are screen defects.

Make sure your monitor supports the resolution and horizontal (kHz) and vertical (Hz) refresh rates as required by the graphics card. Check your current resolution, refresh rate, and color depth settings in the Settings and Monitor tabs in your Display Properties dialog.

Caution:

Ensure that both the graphics card and monitor support the resolution and refresh rates you select. Incompatible resolution/refresh rate selection may result in monitor damage. Refer to your monitor's documentation for recommended resolutions and refresh rates.

The screen image is off-center or there are odd colors.

Try adjusting the brightness, sharpness, contrast, and color balance controls of your monitor.

Try adjusting the centering and positioning controls of your monitor to position the picture on the screen.

Set the monitor's RGB inputs (and sync switches, if this option is available) to 75 Ohms, with the sync set to external.

DFP monitor users: Make sure that the DVI plug of your monitor data cable is digital-only (DVI-D), not integrated analog/digital (DVI-I). Refer to your monitor's documentation and contact your supplier or the manufacturer of the DFP monitor for information on how to obtain a suitable data cable plug.

The operating system warns that the graphics card isn't properly configured.

Make sure that the display resolution and refresh rate settings you have selected are supported by the monitor you have connected.

Check the driver installation and make sure that all software is correctly loaded corresponding to your operating system and applications.

Reinstall the drivers for your graphics card.

There are bus address or interrupt conflicts.

Make sure that the I/O and memory addresses reserved for the graphics board are not used by other hardware devices. The integrated on-board VGA controller of your AMD FirePro card uses the following addresses (hex):

- **I/O Address:** Standard VGA I/O: 3B0-3DF
- **Memory Addresses:** Video RAM: A000-BFFF, Video ROM: C000-C7FF

You cannot change the addresses of your AMD FirePro card. In case of an address conflict, try to modify the I/O address of the add-on card that causes the conflict.

To support the special graphics processor on the AMD FirePro card, the system BIOS should automatically assign a system interrupt to the slot where the card is installed. However, there may be problems if your graphics card does not receive an interrupt or a system interrupt is used for more than one device. In case of problems, check the system configuration utility of your operating system for the interrupt assignments.

Workstation Customer Care

If you experience difficulties with your AMD FirePro product, you can contact AMD Customer Care in the following ways.

Web

The AMD Customer Care Web site has number of helpful resources, including a knowledgebase of FAQs and the AMD FirePro Workstation Graphics Web Ticket Submission Page.

The Web site is complimentary and available at all times. The address is support.ati.com.

E-mail

Customer Care is available by e-mail at tech.support@amd.com. E-mails must have "workstation-support" in the subject line. This service is complimentary for registered users.

Telephone

| Country | Telephone Number | Language/Times | Notes |
|--------------------------------|---------------------|---|---|
| US/Canada East Coast | 1-866-284-2093 | English: 9:00AM - 5:30PM EST (Mon-Thu) 9:00AM - 3:00PM EST (Fri) | Complimentary for registered users. Toll-free. |
| US/Canada West Coast | 408-749-2005 | English: 2:30PM - 5:00PM PST (Mon-Thu) 12:00PM - 4:00PM PST (Fri) | Extended hours for West Coast customers; East Coast toll-free number also available. Complimentary for registered users. International and local toll charges to California will apply. |
| United Kingdom | +44 (0)1276-803299 | English: 10:30 - 17:00 CET (Mon-Fri) | Complimentary for registered users. International and local toll charges to the U.K. will apply. |
| France | 0800-908-621 | French/English: 10:30 - 17:00 CET (Mon-Fri) | Complimentary for registered users. Toll-free. |
| Italy | 800-877-224 | Italian/English: 10:30 - 17:00 CET (Mon-Fri) | Complimentary for registered users. Toll-free. |
| Germany | +49 (0)89-4505-3199 | German/English: 10:30 - 17:00 CET (Mon-Fri) | Complimentary for registered users. International and local toll charges to Germany will apply. |
| Argentina | +0800-333-5277 | Portuguese/Spanish: 7:00AM - 3:30PM EST (Mon-Fri) English: 7:00AM - 7:00PM (Mon-Fri) | Complimentary for registered users. Toll-free. |
| Brazil | +0800-891-9068 | Portuguese/Spanish: 7:00AM - 3:30PM EST (Mon-Fri) English: 7:00AM - 7:00PM (Mon-Fri) | Complimentary for registered users. Toll-free. |
| Mexico | +001800-514-3276 | Portuguese/Spanish: 7:00AM - 3:30PM EST (Mon-Fri) English: 7:00AM - 7:00PM (Mon-Fri) | Complimentary for registered users. Toll-free. |
| Other Latin American Countries | +1-905-882-3277 | Portuguese/Spanish: 7:00AM - 3:30PM EST (Mon-Fri) English: 7:00AM - 7:00PM (Mon-Fri) | Complimentary for registered users. International and local toll charges to Canada will apply. |

Note: Customer Care telephone support lines are closed for regional statutory holidays.

Surface Mail

Advanced Micro Devices Inc.
Attention: Customer Care
1 Commerce Valley Drive East
Markham, Ontario
L3T 7V9 CANADA

This service is complimentary.

Disclaimer

AMD Customer Care will work to resolve your issue and help you to get your product up and running. If your issue is not resolved, our technicians will determine whether the difficulty you are experiencing is the result of the product, whether your product contains a defect, and whether your product should be returned to AMD for warranty service.

AMD Customer Care is unable to assist with refunds, returns, or exchange-specific inquiries. If resolving the problem being experienced is critical to your decision to keep the product, it is your responsibility to ensure that you know and are within the period of time your reseller will allow for refunds, returns, or exchange.

AMD is not responsible for any expense incurred accessing Customer Care. It is expected that customers will review the expense associated with the available support options and will choose the method that best meets their needs and budget.

AMD Customer Care reserves the right to limit support options for products that are not registered or are at End of Life.

Workstation Warranty Service

For warranty service instructions visit ati.amd.com or contact one of our Customer Service Representatives.

Shipping

Before shipping any unit for repair, obtain an RMA number for warranty service.

When shipping your product, pack it securely, show the RMA and serial number of the product on the outside, and ship prepaid and insured.

AMD will not be held liable for damage or loss to the product in shipment.

Standard warranty service consists of repair upon receipt.

AMD reserves the right to replace the product with a serviced product at their sole discretion at any time.

You are responsible for the cost of shipping the product to AMD. AMD pays the cost of returning the product to you.

Products which are repaired under warranty are guaranteed for the remainder of the original warranty period. Repairing or exchanging a product does not start a new

warranty period. If, at the time of repair, a product is already “out of warranty” or within the last 90 days of the warranty period, AMD will guarantee the repair for the full 90 days. All other terms and conditions of the original warranty apply.

Limitations

This warranty is valid only if the online Product Warranty Registration form at ati.amd.com is successfully submitted within 30 days of purchase of said product.

All warranties for this product, expressed or implied, will expire three (3) years from date of original purchase.

All accompanying cables and accessories are warranted for 90 days.

No warranties for this product, expressed or implied, shall extend to any person who purchases the product in a used condition.

The liability of AMD in respect of any defective product will be limited to the repair or replacement of such product. AMD may use new or equivalent-to-new replacement parts. Defective product will be sent in for repair or replacement only. AMD makes no other representations or warranties as to fitness for a particular purpose, merchantability or otherwise in respect of the product. No other representations, warranties or conditions, shall be implied by statute or otherwise. In no event shall AMD be responsible or liable for any damages, including but not limited to the loss of revenue or profit, arising:

- From the use of the product, as a result of any event, circumstance, action or abuse beyond the control of AMD; whether such damages be direct, indirect, consequential, special or otherwise and whether such damages are incurred by the person to whom this warranty extends or a third party
- From the loss of use of the product, as a result of any event, circumstance, action or abuse beyond the control of AMD; whether such damages be direct, indirect, consequential, special or otherwise and whether such damages are incurred by the person to whom this warranty extends or a third party.

Unauthorized repairs to an AMD board level product will void the warranty offered by AMD. AMD reserves the right to refuse to service any product which has been altered, modified, or repaired by non-AMD service personnel.

Additional Accessories

Additional and replacement cables, installation CDs, manuals, and other accessories for AMD products can be purchased from the online AMD store at ati.amd.com/online/accessories.

International Compliance Information

This section details the worldwide compliance information for this product, which is manufactured to be compliant in the regions where it is sold.

AMD products are either Class A or Class B compliant and are indicated accordingly on the compliance label for each product. The following regulatory information applies to Class A and Class B products.

FCC Compliance Information (USA)

Class A

This device complies with Part 15 of the FCC Rules. Operation is subject to the following conditions: (1) this device may not cause harmful interference and (2) this device must accept any interference received, including interference that may cause undesired operation.

Note: This equipment has been tested and found to comply with the limits for a Class A digital device, pursuant to Part 15 of the FCC Rules. These limits are design to provide reasonable protection against harmful interference when the equipment is operated in a commercial environment. This equipment generates, uses, and can radiate radio frequency energy and, if not installed and used in accordance with manufacturer's instructions, may cause harmful interference to radio communications. Operation of this equipment in a residential area is likely to cause harmful interference in which case, the user will be required to correct the interference at his own expense.

Warning:

Changes or modifications to this device not expressly approved by Advanced Micro Devices, Inc. could void the user's authority to operate the equipment.

FCC Part 15, Subpart B, Class A

Class B

This product complies with FCC Rules Part 15. Operation is subject to the following conditions:

- This device may not cause harmful interference.
- This device must accept any interference received, including interference that may cause undesired operation.

This equipment has been tested and found to comply with the limits designed to provide reasonable protection against harmful interference in a residential installation. This equipment generates, uses and can radiate radio frequency energy and, if not installed and used in accordance with manufacturer's instructions, may cause harmful interference to radio communications. However, there is no guarantee that interference will not occur in a particular installation. If this equipment does cause harmful interference to radio or television reception, which can be determined by turning the equipment off and on, the user is encouraged to try to correct the interference by one or more of the following measures:

- Re-orient or relocate the receiving antenna.
- Increase the separation between the equipment and receiver.
- Connect the equipment to an outlet on a circuit different from that to which the receiver is connected.
- Consult the dealer or an experienced radio/TV technician for help.

The use of shielded cables for connection of the monitor to the graphics card is required to ensure compliance with FCC regulations. Changes or modifications to this unit not expressly approved by the party responsible for compliance could void the user's authority to operate this equipment.

Caution:

Changes or modifications not expressly approved by the party responsible for compliance could void the user's authority to operate the equipment.

FCC 15, Subpart B, Class B

For further compliance information:

Advanced Micro Devices, Inc.
1 AMD Place
P.O. Box 3453
Sunnyvale, CA 94088-3453
USA Tel: 408-749-4000

Industry Canada Compliance Statement (Canada)

Class A

This Class A digital apparatus complies with Canadian ICES-003.

Cet appareil numérique de la Classe A est conforme à la norme NMB-003 du Canada.

Class B

This Class B digital apparatus complies with Canadian ICES-003.

Cet appareil numérique de la Classe B est conforme à la norme NMB-003 du Canada.

CE Compliance Information (European Union)

Class A

Warning:

This is a Class A product. In a domestic environment this product may cause radio interference in which case the user may be required to take adequate measures.

EMC Directive 2004/108/EC

CISPR 22/EN 55022—Class A: Limits and methods of measurement of radio disturbance characteristics of Information Technology Equipment.

CISPR 24/EN 55024—Information Technology Equipment—Immunity Characteristics—Limits and Methods of Measurements

Class B

EMC Directive 2004/108/EC

CISPR 22/EN 55022—Class B: Limits and methods of measurement of radio disturbance characteristics of Information Technology Equipment.

CISPR 24/EN 55024—Information Technology Equipment—Immunity Characteristics—Limits and Methods of Measurements

Electrical Safety

Europe: The Low Voltage Directive–2006/95/EC

- EN 60950-1–Safety of Information Technology Equipment

USA/Canada:

- UL 60950-1 (Information Technology Equipment–Safety–Part 1: General Requirements)
- CSA C22.2 No. 60950-1 (Information Technology Equipment–Safety–Part 1: General Requirements)

International:

- IEC 60950-1 (Information Technology Equipment–Safety-Part 1: General Requirements)

To meet UL safety requirements, the computer's maximum room temperature should not exceed 40 °C.

This product complies with the PCI Express 300W Electromechanical Specification – please refer to the manufacturer for additional information. Other relevant input power data will also be available.



VCCI ITE Compliance Information (Japan)

Class A

この装置は、クラスA 情報技術装置です。この装置を家庭環境で使用すると電波妨害を引き起こすことがあります。この場合には使用者が適切な対策を講ずるよう要求されることがあります。

VCCI-A

Translation:

This is a Class A product based on the standard of the VCCI Council. If this equipment is used in a domestic environment, radio interference may occur, in which case, the user may be required to take corrective actions.

VCCI V-3

Class B



この装置は、クラスB 情報技術装置です。この装置は、家庭環境で使用することを目的としていますが、この装置がラジオやテレビジョン受信機に近接して使用されると、受信障害を引き起こすことがあります。

取扱説明書に従って正しい取り扱いをして下さい。

VCCI-B

Translation:

This is a Class B product based on the standard of the VCCI Council. If this is used near a radio or television receiver in a domestic environment, it may cause radio interference. Install and use the equipment according to the instruction manual.

VCCI V-3

KC Certification Information (Korea)



Class A

A급 기기 (업무용 정보통신기기)

이 기기는 업무용으로 전자파적합등록을 한 기기이오니 판매자 또는 사용자는 이 점을 주의하시기 바라며, 만약 잘못판매 또는 구입하였을 때에는 가정용으로 교환하시기 바랍니다.

Translation:

"Class A" Equipment (Business purpose info/telecommunications equipment)

As this equipment has undergone EMC registration for business purpose, the seller and/or buyer is asked to beware of this point and in case a wrongful sale or purchase has been made, it is asked that a change to household use be made.

KN22 and KN24

Class B

B급기기(가정용 방송통신기기)

이 기기는 가정용(B급)으로 전자파적합등록을 한 기기로서 주로 가정에서 사용하는 것을 목적으로 하며, 모든 지역에서 사용할 수 있습니다.

Translation:

"Class B" Equipment (Household purpose info/telecommunications equipment)

As this equipment has undergone EMC registration for household purpose, this product can be used in any area including residential area.

KN22 and KN24

BSMI Certification Information (Taiwan)

Class A

警告使用者：
這是甲類的資訊產品，在居住的環境中使用時，可能會造成射頻干擾，在這種情況下，使用者會被要求採取某些適當的對策。

Translation:

This is a Class A Information Product, when used in residential environment, it may cause radio frequency interference, under such circumstances, the user may be requested to take appropriate countermeasures.



CNS13438

Class B



CNS13438

C-Tick (Australia and New Zealand)



ACMA — Australian Communications and Media Authority

- Radiocommunications Act 1992 (Australia)—per notices of section 182
- AS/ NZS CISPR 22

Product Environmental Compliance

This product may carry a marking similar to those below that indicates its level of compliance with China RoHS standards.



For information on China RoHS, EU RoHS, or EU REACH compliance, please refer to [Product Environmental Compliance](#) on the AMD Web site.

Waste Electrical and Electronic Equipment (WEEE) Directive Compliance (European Union)

This product was manufactured by Advanced Micro Devices, Inc.



Appendix A

Glossary - Workstation Products

2D

Acronym for “two dimensional,” a term applied to computer graphics that are “flat.” Typical desktop applications such as word processors, spreadsheet programs, or other programs that manipulate print or simple graphics (such as pictures or line art) are generally considered to be operating within a 2D environment, even when they include simple three dimensional elements, such as buttons.

3D

Acronym for “three dimensional,” referring to computer graphics that appear to have volume and depth. Various modeling processes take the representation of a three dimensional object provided by the computer program and render it by using various lighting components, applying textures, and setting layers of transparency or opacity as required in order to produce a realistic representation of a three-dimensional object on a two-dimensional display.

Aspect Ratio

The proportions of a display are expressed as a ratio of its width and height. Common ratios include 4:3 for TVs and CRTs, 5:4 for LCDs, and 16:9 for widescreen displays.

Bit Depth

Refers to the number of data bits required to store color information about a pixel. Larger bit depth means a greater range of color information is capable of being encoded into each pixel. For example, 1 binary bit of memory can only encode to either “0” or “1.” So a graphical bit depth of 1 means that the display can only show two colors, the black and white of a monochrome display. Four-bit color depth is capable of displaying 16 colors because there are only 16 different combinations of 4 bits (0000, 0001, 0010... to 1111). Sixteen-bit color is capable of reproducing 65,536 colors, 24-bit color can display up to 16,777,216 individual colors, and 30-bit color can display up to one billion individual colors.

Buffer

A name referring to portions of on-board video memory. One large buffer is always used to display images to the screen; this is the “display buffer.” The rest of offscreen memory is typically used by applications as back buffers, z-buffers, and texture buffers.

Catalyst™ Control Center

Catalyst™ Control Center (CCC) is a graphical user application providing access to the display features contained within the installed AMD hardware and software. CCC can be used to fine-tune various graphics settings, enable or disable connected display devices, change the orientation of a desktop, and much more.

CRT

Acronym for “cathode ray tube,” which is the main component of computer monitors and TVs. Color CRTs use three separate electron beams fired through a shadow mask and onto the back of the glass screen. The electron beams activate separate red, green, and blue values in various strengths in order to produce a colored image.

DisplayPort

DisplayPort is a digital display standard that became a VESA-approved standard in May 2006. HDMI™ is aimed primarily at the consumer electronic market, but DisplayPort was designed with computer displays in mind. It is scalable and extensible in terms of pixel depth and resolution, designed to work as a comprehensive solution both for PCs and notebooks, which currently use different signaling standards (DVI and LVDS). DisplayPort is designed as a long-term comprehensive replacement for VGA, providing a cost-effective, scalable, industry standard which will consolidate external (box-to-box) and internal (LCD panel) display connections.

DVI

Acronym for “Digital Video Interface,” a standard video connection used on many current computer displays. There are three types of DVI connections: DVI-A (analog), DVI-D (digital), and DVI-I (integrated, capable of either analog or digital). It supports high-bandwidth video signals over 160 Hz, so it is most often used for high-resolution displays.

Frame Buffer

The portion of the memory buffer on the graphics card used to store the image being displayed. All rendering processes have been accomplished by this stage and this buffer contains only a one-to-one relationship of the data to be relayed to the display.

Frames Per Second

In terms of 3D graphics, refers to the rate at which the graphic processor can render new screens per second. Higher rates equals better, more naturalistic performance for such things as games set in a 3D environment. Sometimes abbreviated to “fps.”

GPU

GPU is an acronym for “Graphics Processing Unit.” The GPU powers the operations of a graphics card including support for 2D/3D and video.

HDCP

HDCP is an acronym for “High-Bandwidth Digital Copy Protection.” It is a form of digital rights management designed to protect copyright of signals being transported across DVI or HDMI™ connections. Several international regulatory bodies have recommended its incorporation into high-definition display and playback devices.

HDMI™

HDMI™ is an acronym for “High Definition Multimedia Interface.” It is a 19-pin connector used for transferring combined digital audio and video. HDMI™ supports standard, enhanced, and high-definition digital video signals, and is designed for use with VCRs, DVD players, personal computers, and set-top boxes. A DVI adapter can be used to transfer the video signal to an HDMI™-capable display, although audio must be transferred from a different route, as DVI output does not support audio.

HydraVision™

HydraVision™ is AMD's multi-monitor management software, enabling users to manage the display of multiple windows and applications across two or more adjacent monitors. It also includes a range of productivity features designed to effectively manage applications in this environment.

PCI Express® (PCIe®)

The successor standard to the PCI and AGP bus standards, with a significantly faster serial communications system, further opening up bandwidth for more communications between such peripherals as graphics cards and the computer's CPU. PCIe® cards can come in several physical configurations, the fastest currently being X16, which is typically used for graphic cards, and X1, typically used for other peripherals, such as separate multimedia cards.

Pixel

All computer images are made up of tiny dots. Each individual dot is called a pixel, a word created from the term "picture element." A pixel is the smallest indivisible unit of a digital image and can be only a single color. The size of the pixel depends on how the display resolution has been set. The smallest size a pixel can be is determined by the display's dot pitch, which is measured in millimeters (mm).

Refresh Rate

Also referred to as "vertical refresh rate." This is the rate at which a monitor or television can redraw the screen from top to bottom. NTSC television systems have a refresh rate of approximately 60 Hz whereas computer displays typically have refresh rates of 75 Hz or more. At refresh rates of 70 Hz and lower, screen flicker is often noticeable.

Rendering

Rendering refers to the final drawing stages where the 2D image that appears on a display is derived from its 3D descriptions. What appears on the display may look three dimensional, but it is really just a 2D grid of pixels designed to appear that way.

Resolution

The resolution of any display is the number of pixels that can be depicted on screen as specified by the number of horizontal rows against the number of vertical columns. The default VGA resolution of many video cards is capable of displaying 640 rows of pixels by 480 columns. The typical resolution of current displays is set to higher values, such as 1024×768 (XGA), 1280×1024 (SXGA), or 1600×1200 (UXGA).

VGA Connector

A type of graphics connector, sometimes also called an analog connector. It is the most common type of video connector available, consisting of 15-pins set in three rows. VGA is an acronym for "Video Graphics Array," which is also the name for the video resolution mode of 640×480 pixels, the lowest standard resolution supported by virtually all video cards.

