

# Planar UltraLux Series



**PLANAR**<sup>TM</sup>

Copyright © 21 Aug 2014 by Planar Systems, Inc. All rights reserved.  
Contents of this publication may not be reproduced in any form without permission of Planar Systems, Inc.

### Trademark Credits

Windows™ is a trademark of Microsoft Corp.  
All other names are trademarks or registered trademarks of their respective companies.

### Disclaimer

The information contained in this document is subject to change without notice. Planar Systems, Inc., makes no warranty of any kind with regard to this material. While every precaution has been taken in the preparation of this manual, the Company shall not be liable for errors or omissions contained herein or for incidental or consequential damages in connection with the furnishing, performance, or use of this material.

### Warranty and Service Plans

Planar warranty and service plans will help you maximize your investment by providing great support, display uptime, and performance optimization. From post-sale technical support to a full suite of depot services, our services are performed by trained Planar employees. When you purchase a Planar product, you get more than a display, you get the service and support you need to maximize your investment. To find the latest warranty and service information regarding your Planar product, please visit:

<http://www.planarcontrolroom.com/support>

## Warranty Features

- 3-year protection from defects in material and workmanship
- Advanced shipment of replacement part or product
- Access to 24/7 emergency phone support
- Please visit: [http://www.planar.com/support/warranty/standard\\_warranties/](http://www.planar.com/support/warranty/standard_warranties/) for a full warranty review.

### RoHS Compliance Statement

All Planar UltraLux Series displays are fully RoHS compliant.

### ADA Compliance Statement

All Planar UltraLux Series displays are compliant with the Americans with Disabilities Act.

Part Number: 020-1207-00 Rev D

# Table of Contents

Warranty Features .....	ii
<b>Introduction .....</b>	<b>6</b>
Planar UltraLux Series Features .....	7
UltraLux Mounting System.....	8
Control Module.....	8
Integrated Media Player Storage .....	9
LED Technology .....	9
RS232 and LAN With SNMP Monitoring.....	9
Remote Control .....	10
Safety Information .....	11
Important Safety Instructions .....	11
European Union Disposal Information.....	13
Recommended Usage .....	14
Burn-In Versus Temporary Image Retention .....	14
Normal Use Thermal Guidelines.....	15
Using the Display in Flat Orientation .....	15
<b>Installing the Planar UltraLux Series .....</b>	<b>16</b>
Before You Begin.....	16
Tools/Equipment List .....	16
Other Things You May Need .....	16
Plan Your Installation .....	16
Powering On/Off Displays .....	17
Unpacking and Checking Accessories .....	18
Accessory Kit .....	18
Optional Planar-Supplied Accessories .....	19
<b>Wall Mounting LCD Using Planar Profile Mount .....</b>	<b>20</b>
Installing an UltraLux Display on a Wall.....	21
Using the Kickstand Bracket.....	28
<b>Installing Cables .....</b>	<b>29</b>

AC power cord .....	29
IR sensor extender .....	29
<b>Touchscreen Setup .....</b>	<b>30</b>
USB and Power Hook-Up .....	30
Touchscreen MultiTouch Driver Installation .....	31
Touchscreen (PQLabs) MultiTouch Platform Content .....	31
Touchscreen Information .....	31
Calibration .....	31
Utility .....	31
Options .....	32
Uninstalling the MultiTouch Driver .....	32
<b>External Control and Monitoring .....</b>	<b>33</b>
RS232 Communication .....	34
Connecting the RS232 Cable .....	34
RS232 Commands .....	35
<b>SNMP Monitoring .....</b>	<b>39</b>
Sending RS232 Commands Via UDP .....	40
Using WallNet Assistant .....	41
Route Add Command .....	44
Planar UltraLux Remote Monitoring .....	45
Remote Monitoring Home .....	45
Unit Status .....	46
Display Control .....	47
Admin Setup .....	50
Reboot .....	56
On-Screen Display Menus .....	57
Image Menu .....	58
Display Menu .....	60
Sound Menu .....	61
System Menu .....	62

<b>Specifications</b>	64
Signal Compatibility	65
<b>UltraLux Dimensions</b>	66
70" Display Dimensions - Front and Side Views	66
70" Display Dimensions - Rear View	67
70" Rear View - Wall Mount Hangers and Service Panel Locations	68
70" Landscape Wall Mounts - Front and Bottom Views	69
70" Landscape Wall Mounts - Side Views	70
70" Portrait Wall Mounts - Front View	71
70" Portrait Wall Mounts - Side Views	72
70" Touch Front and Side Views	73
80" Display Dimensions - Front and Side Views	74
80" Display Dimensions - Rear View	75
80" Rear View - Wall Mount Hangers and Service Panel Locations	76
80" Landscape Wall Mounts - Front and Bottom Views	77
80" Landscape Wall Mounts - Side Views	78
80" Portrait Wall Mounts - Front View	79
80" Portrait Wall Mounts - Side Views	80
80" Touch Front and Side Views	81
<b>Regulatory Information</b>	82
<b>Customer Support Information</b>	83
Customer Support Contact Information and Hours of Operation	83
Warranty and Service Plans	83
Warranty Features	83
<b>Accessing Planar's Technical Support Website</b>	84

# Introduction

The Planar UltraLux Series is a family of large format 70" and 80" displays which combine style and aesthetics with high performance display technology. From its sleek design to lasting 24 x 7 reliability, the Planar UltraLux is ideally suited for retail brand communications, advertising networks, conference rooms, wayfinding, and other commercial signage applications.

Offered in a wide range of configurations, the Planar UltraLux Series provides the flexibility to specify the ideal display for any environment. With value added features such as interactive touch, edge-to-edge glass front design, and unique mounting options, the UltraLux goes above and beyond for a truly stunning implementation of digital signage.



**Caution:** This manual is intended for use by qualified service persons and end users with experience installing LCD displays.

Planar UltraLux Series is wall mountable in portrait or landscape configurations. Each model within the Planar UltraLux Series is available with six-point multi-touch technology for interactive applications.

## Planar UltraLux Series Features

The Planar UltraLux Series delivers superior 24/7 visual performance with features enabling easy service and installation.

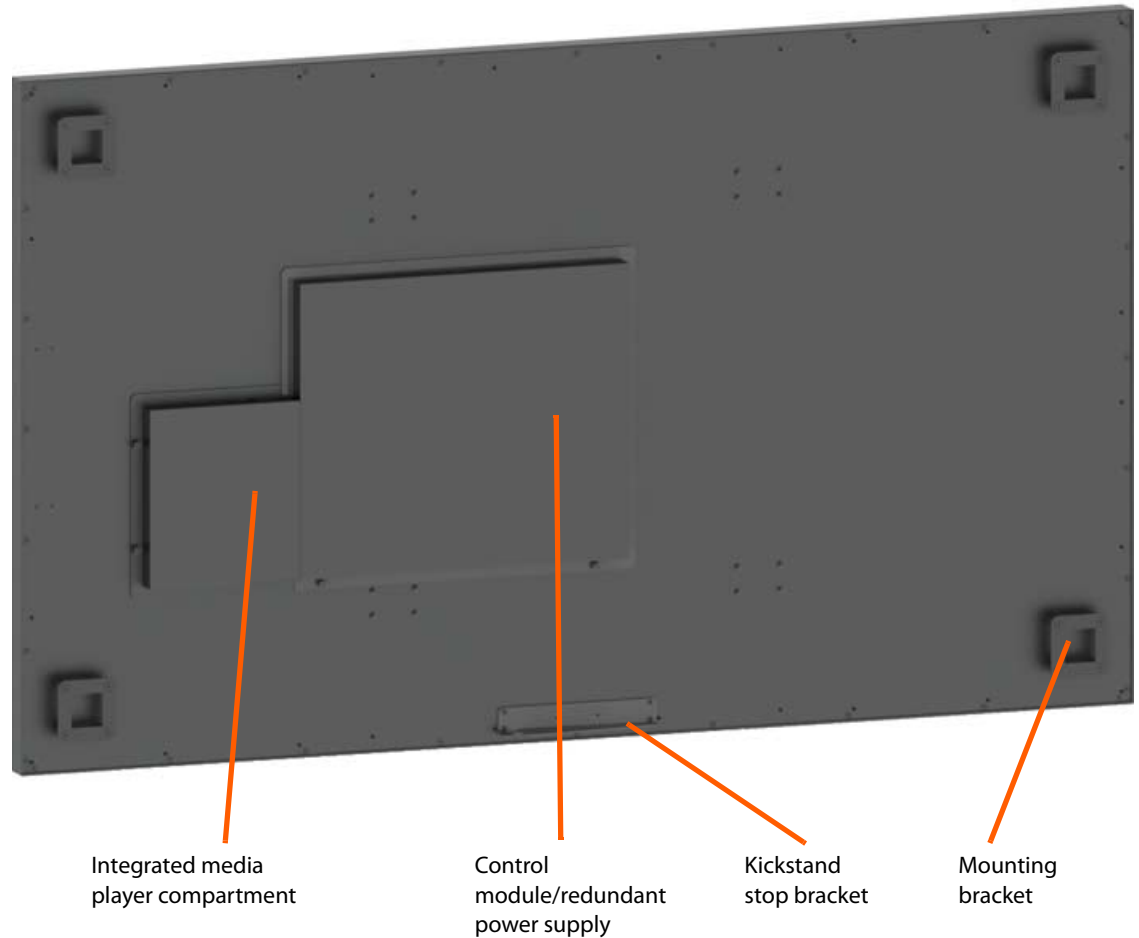

**Caution:** AC power cord needs to be away from the component boxes shown here. This is due to the very low profile of the space between the back of the LCD and the wall.

## UltraLux Mounting System

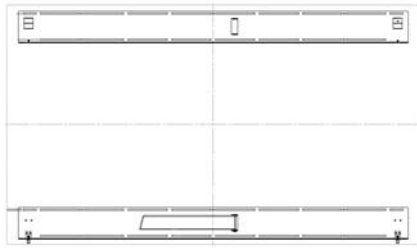

Wall mount brackets - landscape

The Planar Profile™ Mounting System allows for simplified installation. The Profile Mounting System includes two wall brackets and incorporates a kick-stand feature that tilts the display away from the wall for easy access to the

electronics. Eliminating the need to completely remove the display from the wall reduces complexity and service time by up to 70%.



Profile™ Mounting System with kick-stand service mode

## Control Module

On the back of the UltraLux display is a replaceable control module that contains the inputs and outputs shown below. The entire module is designed so that it can be easily replaced in the field without having to remove the LCD display.

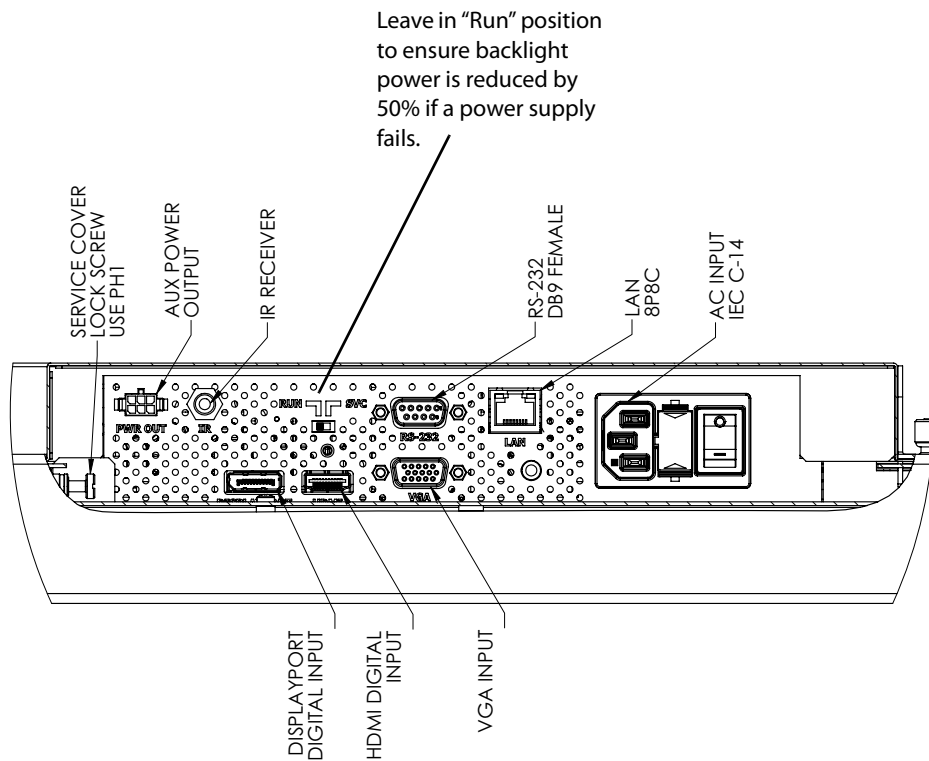



### Redundant Power Supply

A redundant power supply design ensures continuous operation. If one power supply fails, the remaining power supply will continue to power the display helping to ensure uninterrupted operation. Each power supply has an output of 24V.

### Video Board

This contains HDMI, DisplayPort and VGA inputs. It also contains a LAN board with Ethernet and RS232 ports.

### Power Board

This is used to generate the required voltages needed to run the control module.

## Integrated Media Player Storage

Planar UltraLux displays incorporate a 1U media player compartment enabling a fully-integrated digital signage display system that can power a 5V or 12V media player up to 3A on each supply.

## LED Technology

With edge-lit LED technology, the Planar UltraLux Series delivers reduced power consumption and lowered operating costs over the life of the display by up to 60% compared to CCFL technology.

## RS232 and LAN With SNMP Monitoring

Control and status monitoring and integration with enterprise management solutions.

## Remote Control

All on-screen functions can be accessed using the remote control. Note that only the buttons highlighted below are applicable to the UltraLux Series panels.

Turns on/off the AC power to the LCD module.

Mutes the audio.

Four arrow keys move the selector as shown: up, down, left or right.

Press to access on-screen menus.

Select this to choose a source. Also use as the **Back** button when navigating through menus.



## Safety Information

This display was designed with safety in mind. If you don't heed the safety warnings and cautions, you could get hurt. The safety warnings are on stickers in various places in and on the display.

### Important Safety Instructions

- 1** Read these instructions.
- 2** Keep these instructions.
- 3** Heed all warnings.
- 4** Follow all instructions.
- 5** Do not use any of the Planar UltraLux Series products near water.
- 6** Clean the optically bonded protection glass (ERO™) with a 50-50 mix of water and isopropyl alcohol with cheesecloth.
- 7** Do not install near any heat sources such as radiators, heat registers, stoves or other apparatus (including amplifiers) that produce heat.
- 8** Do not defeat the safety purpose of the polarized or grounding type plug. A polarized plug has two blades with one wider than the other. A grounding type plug has two blades and a third grounding prong. The wide blade or the third prong is provided for your safety. When the provided plug does not fit into your outlet, consult an electrician for the replacement of the obsolete outlet.
- 9** Protect the power cord from being walked on or pinched particularly at plugs, convenience receptacles and the point where they exit from any of the Planar UltraLux Series products.
- 10** The AC input is protected by a 5A slow blow fuse located in the AC inlet module. The fuse is replaceable and the recommended fuse is Schurter part number 0034.3124.
- 11** Only use the attachments/accessories specified by the manufacturer.
- 12** Unplug all Planar UltraLux Series products during lightning storms or when unused for long periods of time.
- 13** Ensure that the RUN/SVC switch on the control module is in the "Run" position unless the display is being serviced. This will ensure that if one power supply fails that the backlights will be reduced by 50% to save power.

- 14** You must follow all National Electrical Code regulations. In addition, be aware of local codes and ordinances when installing your system.
- 15** Refer all servicing to qualified service personnel. Servicing is required when any of the Planar UltraLux Series displays have been damaged in any way, such as the AC power cord or plug is damaged, liquid has been spilled or objects have fallen into the display, or if the displays have been exposed to rain or moisture, do not operate normally or have been dropped.
- 16** Keep the packing material in case the equipment should ever need to be shipped.
- 17** Wall mounts must be secure. The wall must be strong enough to hold all displays, mounts, brackets and cables.
- 18** Slight pressure on the LCD will cause distortion of the image. Heavier pressure will cause permanent damage. Planar UltraLux Series configurations should be mounted in a way that viewers cannot insert small objects in the openings that will create hazards by contacting bare conductive parts.

# European Union Disposal Information

English

- Disposal of old Electrical & Electronic Equipment (Applicable throughout the European Union and other European countries with separate collection programs)

This symbol found on your product or on its packaging, indicates that this product should not be treated as household waste when you wish to dispose of it. Instead, it should be handed over to an applicable collection point for the recycling of electrical and electronic equipment. By ensuring this product is disposed of correctly, you will help prevent potential negative consequences to the environment and human health, which could otherwise be caused by inappropriate disposal of this product. The recycling of materials will help to conserve natural resources.



This symbol is only valid in the European Union. If you wish to discard this product, please contact your local authorities or dealer and ask for the correct method of disposal.

Español

- Deshecho de equipos eléctricos y electrónicos (aplicable a la Unión Europea y a otros países europeos con programas de reciclaje independientes)

La presencia de este símbolo en el propio producto o en su material de embalaje, indica que no se debe tratar como residuo doméstico cuando desee deshacerse de él. En su lugar, debe entregarlo en el punto limpio correspondiente de reciclaje de equipos eléctricos y electrónicos. Asegurándose de que este producto se desecha de forma correcta, ayudará a evitar posibles consecuencias negativas para la conservación del medioambiente y la salud humana, consecuencias que podrían darse si se desecha del producto de forma inadecuada. El reciclado de materiales ayuda a conservar los recursos naturales.



Este símbolo solamente es válido en la Unión Europea. Si desea deshacerse de este producto, póngase en contacto con las autoridades locales o con su distribuidor y pida información sobre el método de disposición adecuado.

Português

- Eliminação de equipamentos eléctricos e electrónicos usados (aplicável na União Europeia e noutros países europeus com programas próprios de recolha destes equipamentos)

Este símbolo, colocado no produto ou na respectiva embalagem, indica que o produto não deve ser tratado como lixo doméstico aquando da sua eliminação. Em vez disso, deve ser entregue num ponto de recolha de equipamentos eléctricos e electrónicos para posterior reciclagem. Ao garantir a correcta eliminação deste produto, estará a evitar consequências potencialmente negativas tanto para o ambiente como para a saúde humana. A reciclagem de materiais ajuda a preservar os recursos naturais.



Este símbolo apenas é válido na União Europeia. Se quiser eliminar este produto, contacte as entidades locais ou o seu fornecedor para ficar a saber qual o método de eliminação correcto.

Svenska

- Avfall av förbrukad elektrisk och elektronisk utrustning (Tillämpbart i hela Europeiska unionen och andra europeiska länder med separata samlingsprogram)

Den här symbolen som finns på din produkt eller på dess förpackning påvisar att produkten inte ska behandlas som hushållsavfall när du vill slänga bort den. Istället ska den lämnas över till en lämplig uppsamlingspunkt för återvinning av elektriska och elektroniska utrustningar. Genom att tillförsäkra att den här produkten återvinns på ett riktigt sätt hjälper du till med att förhindra möjliga negativa konsekvenser för miljön och mänsklig hälsa. Det kan annars orsakas på grund av olämplig sophantering av den här produkten. Återvinning av material kommer att hjälpa till att bevara naturtillgångar.



Den här symbolen är endast giltig inom den Europeiska unionen. Om du vill slänga bort den här produkten ska du kontakta lokala myndigheter eller återförsäljare, och fråga efter lämplig avfallsmetod.

Français

- Mise au rebut des équipements électriques et électroniques usagés (Valable dans l'ensemble de l'Union Européenne ainsi que dans les pays européens disposant de programmes distincts de collecte des déchets)

Ce symbole appliqué sur votre produit ou sur son emballage indique que ce produit ne doit pas être traité comme un déchet ménager lorsque vous voulez le mettre au rebut. Il doit au contraire être remis à un site de collecte agréé pour le recyclage des équipements électriques et électroniques. En veillant à ce que ce produit soit mis au rebut de façon adéquate, vous contribuerez à prévenir les conséquences potentiellement négatives sur l'environnement et sur la santé humaine qui risqueraient de se produire en cas de mise au rebut inappropriée de ce produit. Le recyclage des matériaux contribuera également à économiser les ressources naturelles.



Ce symbole n'est valable que dans l'Union Européenne. Si vous souhaitez mettre ce produit au rebut, veuillez prendre contact avec les autorités locales ou avec votre revendeur et renseignez-vous sur la méthode de mise au rebut correcte.

Italiano

- Smaltimento delle attrezzature elettriche ed elettroniche usate (applicabile in tutta la Comunità Europea ed altri Paesi Europei che applicano programmi di raccolta differenziata)

Il simbolo trovato sul prodotto, o sulla sua confezione, indica che il prodotto non può essere trattato come i domestici quando è il momento di smaltirlo. Al contrario, deve essere consegnato ad un centro di raccolta specializzato nel riciclaggio di attrezzature elettriche ed elettroniche. Assicurando che il corretto smaltimento di questo prodotto, si aiuterà a prevenire potenziali conseguenze negative sull'ambiente e sulla salute umana, che possono essere provocate da uno scorretto smaltimento di questa attrezzatura. I materiali riciclati aiuteranno a conservare le risorse naturali.



Questo simbolo è valido solo nell'Unione Europea. Per smaltire questo prodotto, mettersi in contatto con le autorità locali – o con il rivenditore – e chiedere informazioni sul corretto metodo di smaltimento.

Polski

- Uzuwanie zużytego sprzętu elektrycznego i elektronicznego (Dotyczy krajów Unii Europejskiej i innych krajów europejskich z oddzielnymi programami zbiórki odpadów)

Obecność tego symbolu na produkcie lub na opakowaniu z produktem oznacza, że tego produktu nie można wyrzucić razem z odpadkami domowymi. Należy go przekazać do punktu zbiórki w celu poddania recyklingowi podzespołów elektrycznych i elektronicznych. Usunięcie tego produktu w prawidłowy sposób, pomoże w zabezpieczeniu przed negatywnym wpływem odpadów na środowisko i zdrowie ludzi, spowodowanym przez niewłaściwe usuwanie produktu. Przelazanie materiałów pomaga w zachowaniu zasobów naturalnych.



Ten symbol obowiązuje wyłącznie w krajach Unii Europejskiej. Informacje dotyczące prawidłowej metody usunięcia tego produktu, można uzyskać u władz lokalnych lub u dostawcy.

Suomi

- Vanhjojen sähkö- ja elektroniikkalaitteiden hävittäminen (Sovellettu kaikkialla Euroopan unionin alueella, sekä muissa Euroopan maissa, joilla on erilliset keräysohjelmat)

Jos tuotteessa tai sen pakkauksessa on tämä symboli, sitä ei pidä hävittää tavallisella tavalla kotitalousjätteinä, vaan se kuuluu toimittajan sähkö- ja elektroniikkalaitteiden kierrätyspisteeseen. Varmistamalla, että tämä tuote hävitetään asiaankuuluvalla tavalla autat estämään mahdollisia ympäristölle ja ihmisille koituvia negatiivisia seurauksia, joita sen vääräntäminen hävittäminen voi aiheuttaa. Materiaalien kierrättäminen auttaa säilyttämään luonnonvarjoja.



Tämä symboli on voimassa ainoastaan Euroopan unionin alueella. Jos haluat hävittää tämän tuotteen, ota yhteyttä paikallisiin viranomaisiin tai jälleenmyyjään ja tiedustele asiaankuuluvia hävittämistietoimenpiteitä.

Dutch

- Entsorgung von elektrischen & elektronischen Altgeräten (geltend für die Europäische Gemeinschaft und andere europäische Länder mit separaten Sammelprogrammen)

Dieses Symbol, zu finden auf Ihrem Produkt oder dessen Verpackung, macht Sie darauf aufmerksam, dass dieses Produkt bei der Entsorgung nicht als Hausmüll behandelt werden darf. Statt dessen sollte es an eine Sammelstelle zum Recycling von elektrischen und elektronischen Altgeräten gegeben werden. Helfen Sie mit, potenziell schädliche Einflüsse auf Umwelt und Gesundheit, die durch eine unsachgemäße Entsorgung dieses Produktes entstehen können, zu vermeiden und entsorgen Sie dieses Produkt ordnungsgemäß. Recycling hilft, natürliche Rohstoffe einzusparen.



Dieses Symbol ist nur innerhalb der europäischen Gemeinschaft gültig. Wenn Sie dieses Produkt entsorgen möchten, wenden Sie sich bitte an Ihre örtliche Behörde und fragen Sie nach der ordnungsgemäßen Entsorgungsmethode.

Nederlands

- Verwijderen van oude elektrische en elektronische apparatuur (toepaselijk in de volledige Europese Unie en andere Europese landen met afzonderlijke programma's voor afvalverzameling)

Dit symbool dat op het product of zijn verpakking is aangebracht, geeft aan dat dit product niet mag worden behandeld als huishoudelijk afval als u het wilt wegwerpen. U moet het afgeven bij een specifiek verzamelpunt voor de recyclage van elektrische en elektronische apparatuur. Door te garanderen dat u dit product op de correcte manier wegwerpt, helpt u potentiële negatieve gevolgen voor het milieu en de menselijke gezondheid, die zouden kunnen worden veroorzaakt door een onrechtmatig wegwerpen van het product, te voorkomen. De recyclage van materialen helpt het behoud van natuurlijke bronnen.



Dit symbool is alleen geldig in de Europese Unie. Als u dit product wenst weg te gooien, dient u contact op te nemen met uw lokale instanties voor details over de gepaste methode voor afvalverwijdering.

Waste Electrical and Electronic Equipment (WEEE) Directive In the European Union, this label indicates that this product should not be disposed of with household waste. It should be deposited at an appropriate facility to enable recovery and recycling. EEE complies with Directive 'Regulation on the Restriction of the Use of Certain Hazardous Substances in Electrical and Electronic Equipment'

Waste Electrical and Electronic Equipment (WEEE) Directive In the European Union, this label indicates that this product should not be disposed of with household waste. It should be deposited at an appropriate facility to enable recovery and recycling. EEE complies with Directive 'Regulation on the Restriction of the Use of Certain Hazardous Substances in Electrical and Electronic Equipment'

Waste Electrical and Electronic Equipment (WEEE) Yönergeleri Avrupa Birliği'nde bu etiket, ürünün ev elektroniği aletleri atıkları ile imha edilemeyeceğini gösterir. Kurtarmak ve geri dönüşümünü sağlamak için uygun şartlarda saklanması gerekir. EEE Yönetmeliğine Uygundur Ve Elektronik Eşyalarda Bazı Zararlı Maddelerin Kullanımının Sınırlanmasında Dair Yönetmelik.

Waste Electrical and Electronic Equipment (WEEE) Yönergeleri Avrupa Birliği'nde bu etiket, ürünün ev elektroniği aletleri atıkları ile imha edilemeyeceğini gösterir. Kurtarmak ve geri dönüşümünü sağlamak için uygun şartlarda saklanması gerekir. EEE Yönetmeliğine Uygundur Ve Elektronik Eşyalarda Bazı Zararlı Maddelerin Kullanımının Sınırlanmasında Dair Yönetmelik.

## Recommended Usage

The UltraLux series uses commercial grade LCD panels, and is designed for 24/7 operation. With certain static images and extreme conditions, a slight amount of temporary image retention may occur. To minimize this possibility, it is recommended that either static images be changed occasionally (for example to a different screen layout, or a black screen), or that a periodic display shutdown be programmed using RS232 commands or the UltraLux Remote Monitoring software. In order to get the most out of your LCD modules, use the following recommended guidelines to optimize the display.

### Burn-In Versus Temporary Image Retention

Burn-in causes the screen to retain an image essentially forever, with little or no way to correct the problem. Under normal use, an LCD module will not experience burn-in, as plasma displays do, nor will it retain images in any way.

Normal use of an LCD module is defined as displaying continuously changing video patterns or images. However, LCD modules can experience *temporary* image retention when recommended usage guidelines are not followed.

#### What is Temporary Image Retention?

Temporary image retention (TIR) can occur when a static image is displayed continuously for extended periods of time. An electrical charge differential may build up between the electrodes of the liquid crystal, which causes a negative-color video image (color-inverted and brightness-inverted version of the previous image) to be retained when a new image is displayed. This behavior is true for any LCD device from any LCD manufacturer.

TIR is not covered under warranty. See standard warranty terms and conditions for details. Here are some guidelines to help you avoid TIR:

- Use the LCD module to show a screen saver, moving images or still pictures that change regularly. When using high-contrast images, reposition the images frequently.
- Turn off the UltraLux Series when it is not in use. There are a couple of ways to do this automatically. See "Powering On/Off Displays" on page 17 more information. To use serial commands, see "RS232 Communication" on page 34.

## Normal Use Thermal Guidelines

Normal use of the LCD module and power supply module are defined as operating in the open air to prevent heat buildup, and without direct or indirect heat sources such as lighting fixtures, heating ducts, or direct sunlight that can cause the modules to experience high operating temperatures. For all modules, do not block fans or ventilation openings. If the LCD module will be installed in a recessed area with an LCD surround or enclosure, ensure adequate openings are applied for proper air flow and ventilation.

At 2000 meters or below, the maximum ambient operating temperature for the LCD module cannot be above 104° F (40° C) and 35° C for 80" portrait, nor below the minimum ambient operating temperature of (32° F) 0° C. If one of these conditions exists, it is up to the installer to ensure that module placement is changed, thermal shielding is provided and/or additional ventilation is provided to keep the display within its nominal operating parameters.

### Cooling Requirements

For optimal performance, active cooling by the installer should be planned for when the ambient temperature anywhere in the display is predicted to be above the specified ambient temperature for the display.

## Using the Display in Flat Orientation

The UltraLux is not recommended for use in flat orientation for tabletop, floor, or ceiling installations. LCD panels of this size are at risk of panel deflection, which can cause cosmetic sagging, brightness uniformity issues, and a shortened life span.

# Installing the Planar UltraLux Series

This section explains how to install a Planar UltraLux display. We suggest that you read this entire section before you attempt an installation.

## Before You Begin

Make sure you have all the items in the following lists before you begin unpacking and installing your Planar UltraLux Series.

### Tools/Equipment List

Depending on your installation, you may need one or more of the following items. Note that depending on the size of the display, this list may be different.

- #1 and # 2 Phillips screwdriver
- Drill and bits
- Nut drivers
- Pencil
- Digital/laser level
- Ladders/lift
- Back brace
- Stud finder (if hanging LCD modules on a wall)

### Other Things You May Need

- A 50-50 mix of water and isopropyl alcohol, as well as cheesecloth to clean the displays.
- At least two capable people to lift LCDs into place.

### Plan Your Installation

You should have a detailed plan of how the UltraLux is to be installed. The plan should include calculations for the following:

- Floor/wall load. Make sure the floor/wall is strong enough to support the weight of the UltraLux Series.
- AC receptacle in safe zone where boxes are to be stored.



## Powering On/Off Displays

There are several ways to turn the UltraLux Series on or off:



- Use the on/off switch on the AC power inlet
- Use the power button on the remote control
- Use the RS232 commands
- Use the UltraLux Remote Monitoring embedded software via Ethernet

## Unpacking and Checking Accessories

The UltraLux includes the LCD and an accessory kit. A wall mount kit can be purchased separately.

**Note:** Screws should be no less than 1/4" in diameter. You will need a minimum of eight screws for the top mounting bracket and a minimum of four for the bottom kickstand bracket. Additional screws may be needed depending on your installation.

### Accessory Kit

Part	Description	Picture
AC power cord	90 degree low profile power cord.	
Remote control	Used to turn on/off displays, as well as to navigate through on-screen menus.  <b>Note:</b> Batteries are included and installed.	
USB drive	Contains the Planar UltraLux Series Installation Guide.	

<b>Part</b>	<b>Description</b>
IR extender cable	Used to receive signals from the remote

**Picture**

## Optional Planar-Supplied Accessories

The following optional items are available to order as part of your installation:

- Planar ContentSmart™ Media Player
- Profile™ Wall Mount

# Wall Mounting LCD Using Planar Profile Mount

Before installation, keep the following points in mind:

- These displays are heavy. Make sure that you have adequate studs to support the weight of each display if installing on a wall.
- The UltraLux must be installed on a flat surface.
- Use supplied UltraLux mounting template for top and bottom bracket installation.
- The wall mounts for a landscape and portrait installation look different. However, the process to install them is exactly the same.
- The Planar Profile mount is not designed for tabletop installations.

## Installing an UltraLux Display on a Wall

**Caution:** For whatever structure is used to mount the display, be sure that it is sufficiently engineered to handle the weight of the display. Also be sure to purchase the correct hardware needed to support the display mounted to that structure.

- 1 Find the center point of the display on the wall where you intend to install it.

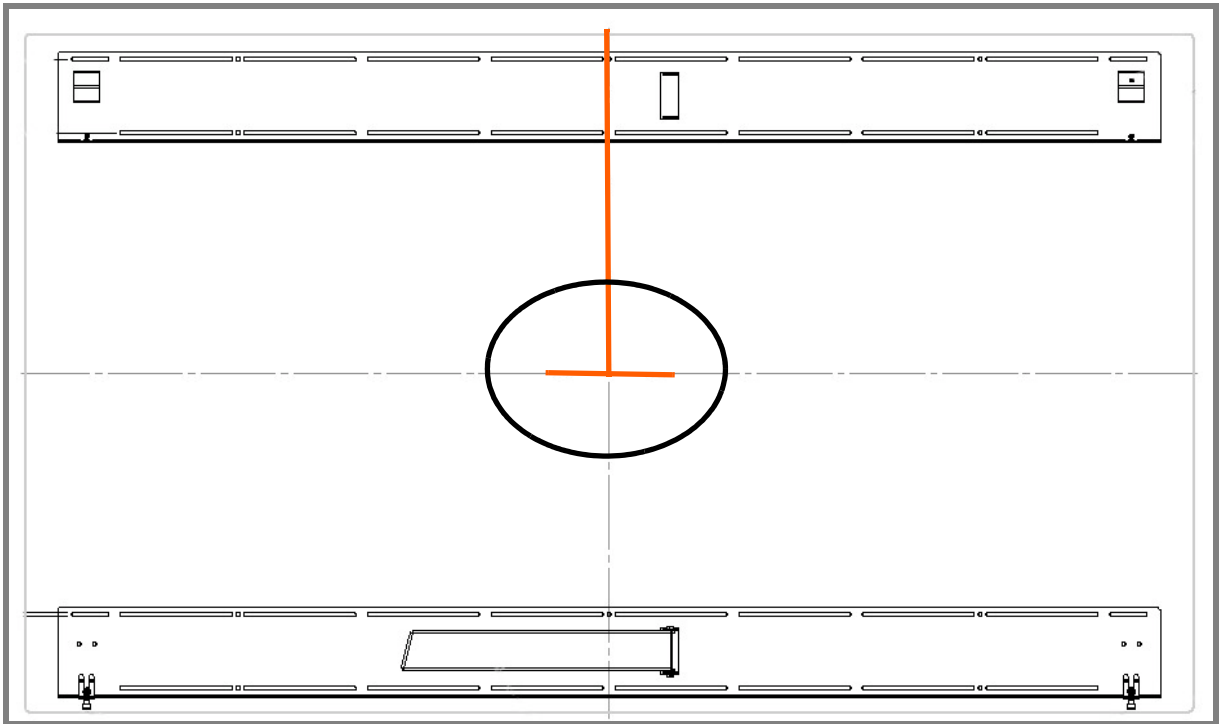

- 2 Draw a short (about 1") horizontal line and then a vertical line to match the edge of the display.

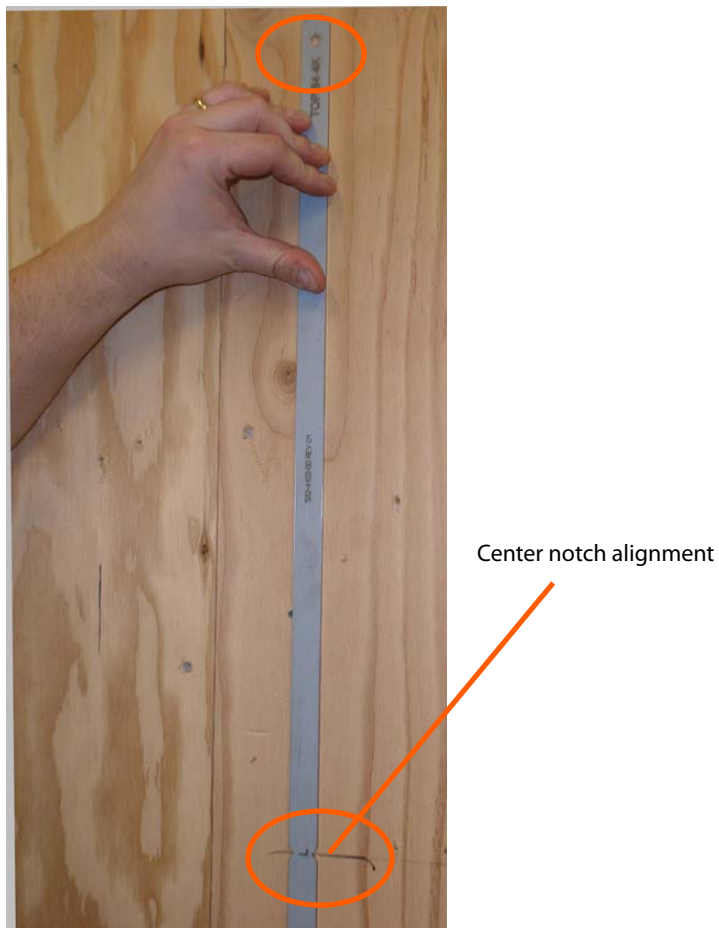

- 3 Use the provided template to determine the center points of the wall mounts. The "V" notches are labeled "L" for a landscape display or "P" for a portrait display. Use the appropriate "V" notch to align with the horizontal line drawn in the previous step.

- 4 In the hole marked "Top" on the template, mark the center of the hole on the wall.



**Note:** If you are installing a landscape display and the template is too long, you can break the template at the notch labeled "P"

- 5 Let the template hang vertically so it is plumb, as the bottom hole in the template determines where the bottom mount will be installed.
- 6 Screw the appropriate hardware into the bottom hole of the template that corresponds with your display orientation.
- 7 Remove each screw and the template.

- 8 Line up the middle hole of the top wall mount with the screw hole drilled from the template.



**Note:** This picture shows mounts for a landscape installation.

- 9 Tighten the screw into the mount.
- 10 Use a level to make sure the mount is level.
- 11 Then install additional screws as needed.

**Note:** Screws installed near the mount hooks provide the best support.

- 12 Install the center screw in the bottom mount and repeat steps 10-11 for any additional screws that you want to install. Note that there are open mount channels on the brackets. So you can install the screws wherever necessary along those channels.



**13** Install the kickstand bracket to the back of the display using four M4 x 8 panhead screws.



Landscape holes for kickstand bracket installation

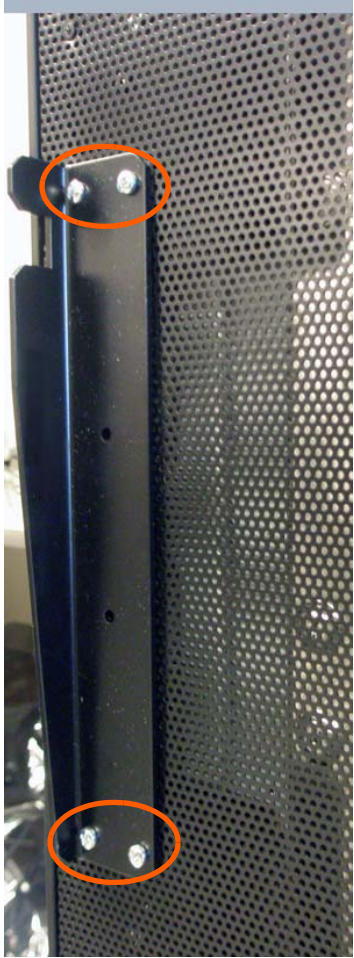

Portrait kickstand installed on display

- 14 Using three strong people, carefully hang the back of the display onto the top wall mount bracket using the square brackets on the back of the display.

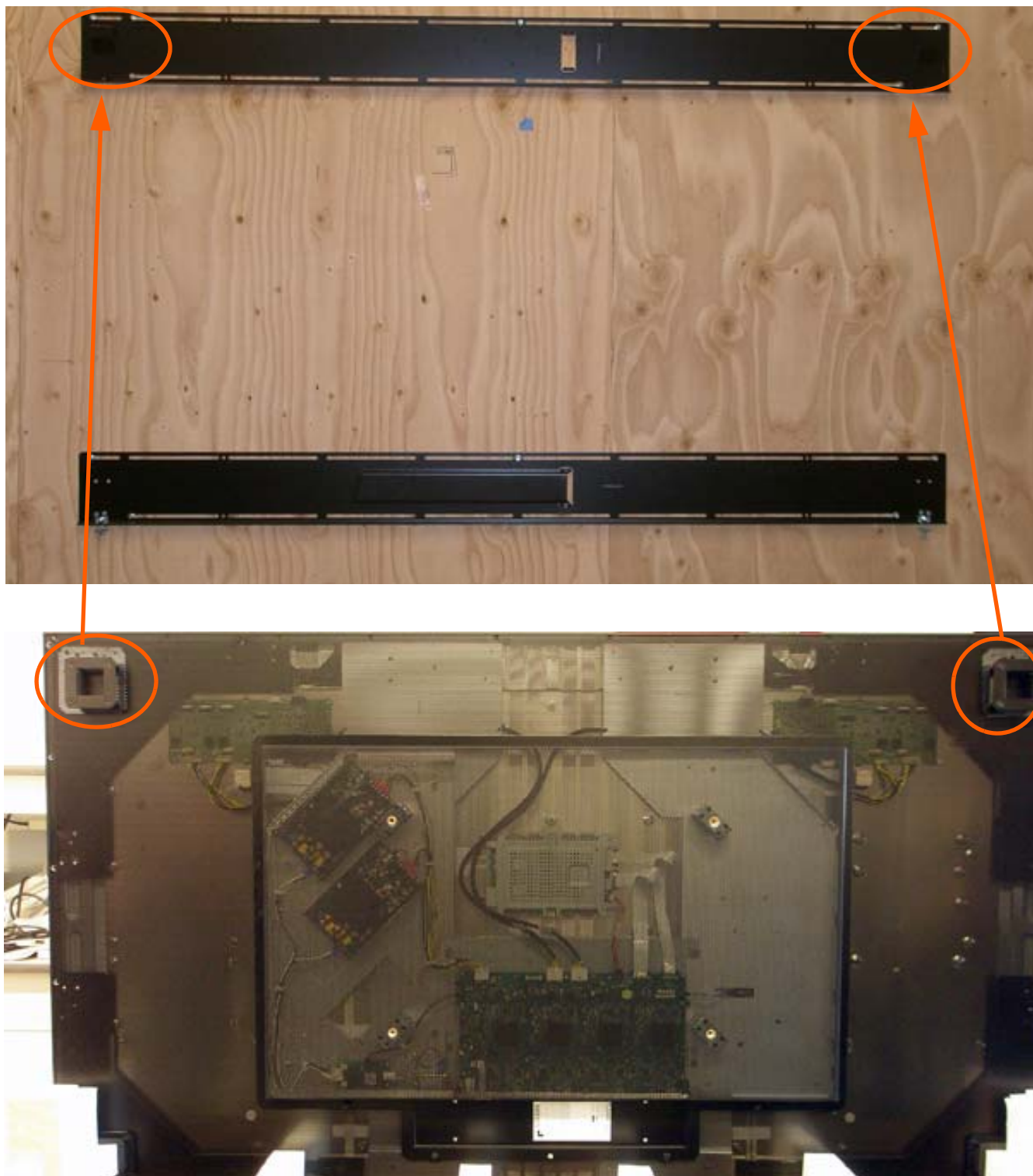

**Caution:** Be sure these are securely hung, as the top of the wall mount will hold most of the weight of the display.

- 15** On the bottom wall mount, there is locking hardware in the lower corners of the mount. Push the hardware up and finger tighten the captive screws on the bottom to secure the display to the wall.



## Using the Kickstand Bracket

The kickstand bracket is used for service mode, without having to remove the display from the wall. Use the following instructions to put the display in service mode.

- 1 Loosen the captive locking screws on both sides of the bottom mount.



- 2 Pull the display out and then swing out the kickstand to hold it in place. The kickstand will nest into the kickstand bracket notch.

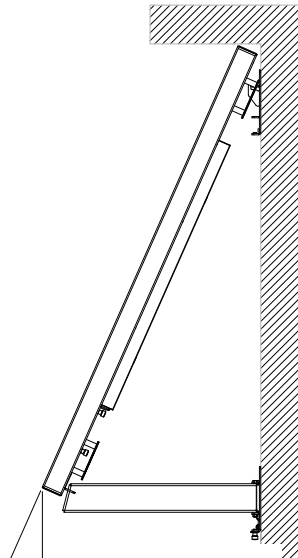
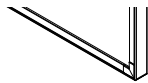

Service position -  
with kickstand  
supporting display





# Installing Cables

The two cables included with the UltraLux are the AC power cord and the IR sensor extender.

## AC power cord

The AC cord is installed into the back of the control module. Depending on your setup, you may need additional cables for media player integration, as well as for sending RS232 commands.

## IR sensor extender

In order for the remote control to work, you need to connect the wired IR module to the display, also on the bottom of the I/O panel. Then place the IR receiver in the desired place on or near the display.

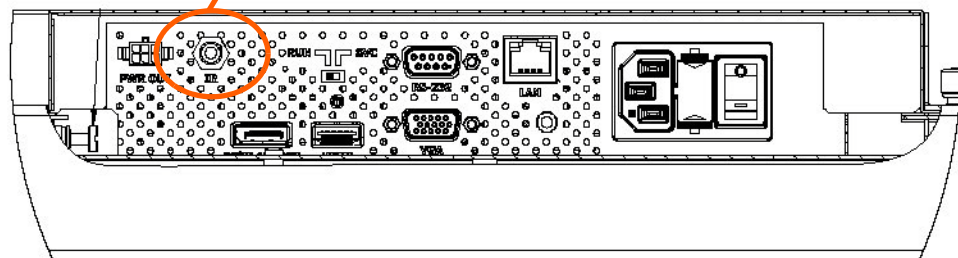
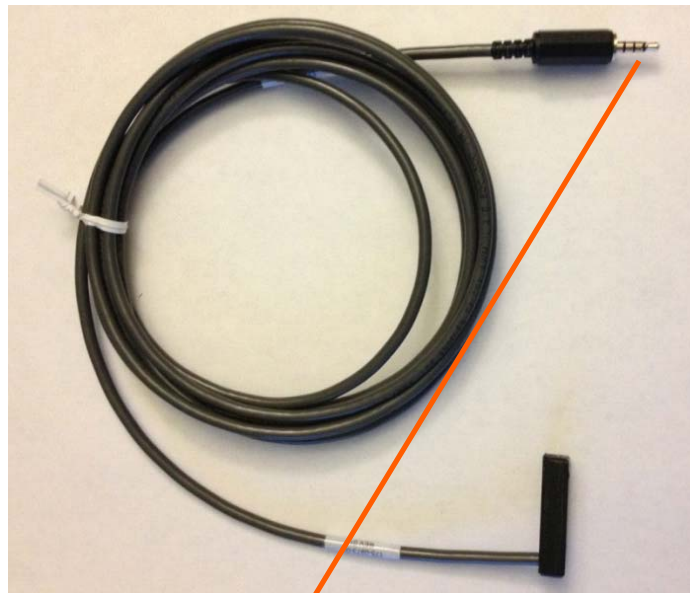

# Touchscreen Setup

## USB and Power Hook-Up

- 1 Using the display service kickstand, swing out the display. If you are only using the mount, make sure you have at least 1" clearance to connect the USB and power.
- 2 Plug in the 5V, 4A Power supply connector to the touchscreen power connector.

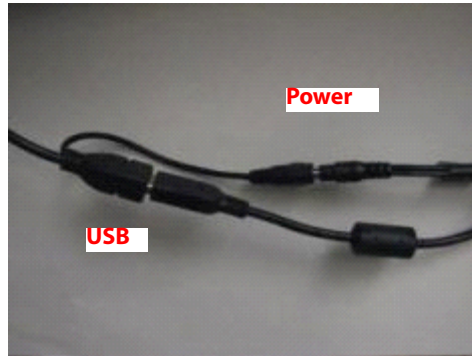

**Note:** USB and Power connection to the touchscreen.

- 3 Connect the 5V line cord to the power adapter.
- 4 Plug one end of the USB cable to the USB connector on the touchscreen and the other end to the PC.



**Note:** USB and Power connection to the touchscreen.

## Touchscreen MultiTouch Driver Installation

- 1 With the PC on, plug in the USB memory stick to the USB drive.
- 2 Locate and open the USB drive.
- 3 Double-click on the “mt\_driver\_kitV4.1212RC2” to install the driver.
- 4 Follow installation prompts until driver installation is complete.

Once driver installation is complete, the touchscreen is ready for use.

## Touchscreen (PQLabs) MultiTouch Platform Content

The PQLabs Software is used for troubleshooting and calibration. The different menus are described below.

- 1 On the PC, select the **Start** menu, **All Programs** and then **PQLabs Software**.
- 2 Click on “MultiTouch Platform” to open the PQLabs MultiTouch Platform window.

### Touchscreen Information

- Serial Number – Displays the serial number of the connected touchscreen.
- Firmware Version – Displays the firmware version of the touchscreen selected under the “Serial Number” dropdown menu.
- Touch Points – Displays the number of touch points for which the touchscreen is capable.
- Status – Displays the current status of the touchscreen.

### Calibration

- Calibration – Starts a 4-point calibration of the touchscreen. Perform the programmed touchscreen calibration process. At the conclusion of the calibration routine your touchscreen device is ready to use and will perform with accurately positioned touch points.
- Reset Calibration – Resets calibration to factory default settings.

### Utility

- Diagnose – Starts the “MultiTouchDoctor” program. This can be used to troubleshoot issues with the touchscreen.

## Options

- Default settings on options have the following programs enabled: Tuio Support, Flash Tuio Support, Handwriting Optimization, Enable Windows Native Touch, Enable Mouse/Keyboard Simulation, and Launch When Windows Starts Up.
- Flexible Scan Rate is at a default setting.

## Uninstalling the MultiTouch Driver

- 1 On the PC, select the **Start** menu, **All Programs** and then **PQLabs Software**.
- 2 Click on the MultiTouch Driver.
- 3 Select the Uninstall option.



---

# External Control and Monitoring

In addition to using the UltraLux remote control and display, there are other methods of controlling the UltraLux externally:

- Using a serial (RS232) link to send commands and to receive responses to those commands.
- Using SNMP (Simple Network Management Protocol) to monitor the device status.
- Using Remote Monitoring software via a web browser.

## RS232 Communication

RS232 control is not necessary for operation, but is a convenient way to control displays from a computer at a distance. If your installation will not use RS232 control, skip this section. Most things you can do with the remote, you can do with RS232 commands. Plus, you can send inquiries to the displays and find out the current settings and values. RS232 connections are made with standard straight-through cables.

### Connecting the RS232 Cable

The RS232 cable will connect either to a PC or a media player, depending on your setup.

## RS232 Commands

The following table provides the RS232 commands that can be used.

Keep the following points in mind:

- **Command length:** 8 bytes (64 bits) for "Set" Commands, 4 bytes for "Get" Commands
- **Required check sum for each command:** 100h (the last byte value is chosen to force the check sum to 100 hex)
- The baud rate is 19200 (8 data bit, 1 stop bit, no parity, no flow control)
- **Example in hex for "Set Backlight Brightness to 80":** 08 22 00 00 00 00 50 86 (where green bytes are the command, blue is the value, red makes the check sum = 100h)

Item	Command Description	Command Value in hex	Command Result
1	Set Power to "off"	08 22 FE 00 00 00 00 D8	video board is set to soft power off mode; backlight off
2	Set Power to "on"	08 22 FD 00 00 00 00 D9	video board is set to soft power on mode; backlight on if video source is present or when first searching for video source
3	Get Power Status	04 21 16 C5	returns "Power: ON" if on; "Power:" if off; "Power: OFF" if on but no video source present
4	Set Backlight Brightness to "X" (1 to 100)	Set to 80: 08 22 00 00 00 00 50 86	backlight brightness set to commanded value
5	Get Backlight Brightness	04 21 08 D3	returns "Backlight = value"
6	Set Contrast to "X" (0 to 100)	Set to 40: 08 22 01 00 00 00 28 AD	contrast set to commanded value (note: contrast changes are not saved when hard power is turned off—known bug)
7	Get Contrast	04 21 09 D2	returns "Contrast = value"
8	Set Sharpness to "X" (-4 to 4)	Set to -4: 08 22 03 00 00 00 00 D3	sharpness set as commanded (for -4 a value of 0 is used; for 4, 8 is used)
9	Get Sharpness	04 21 0A D1	returns "Sharpness = value" where value is Sharpness setting + 4

10	Set Color Temp to "4200K"	08 22 04 00 00 00 02 D0	color temp set to commanded value
11	Set Color Temp to "5000K"	08 22 04 00 00 00 03 CF	color temp set to commanded value
12	Set Color Temp to "6500K"	08 22 04 00 00 00 04 CE	color temp set to commanded value
13	Set Color Temp to "7500K"	08 22 04 00 00 00 05 CD	color temp set to commanded value
14	Set Color Temp to "9300K"	08 22 04 00 00 00 06 CC	color temp set to commanded value
15	Get Color Temp	04 21 0B D0	returns "Color Temp = value" where value is 2 for 4200K, 3 for 5000K, 4 for 6500K, 5 for 7500K, 6 for 9300K
16	Set Red to "X" (0 to 100)	Set to 50: 08 22 0E 00 00 00 32 96	red set to commanded value (use the Red/Green/Blue set commands to get custom color temperatures)
17	Get Red	04 21 0C CF	returns "Red Color = value"
18	Set Green to "X" (0 to 100)	Set to 20: 08 22 0F 00 00 00 14 B3	green set to commanded value
19	Get Green	04 21 0D CE	returns "Green Color = value"
20	Set Blue to "X" (0 to 100)	Set to 80: 08 22 10 00 00 00 50 76	blue set to commanded value
21	Get Blue	04 21 0E CD	returns "Blue Color = value"
22	Set Input to "DisplayPort"	08 22 02 00 00 00 00 D4	set the input source to DP, which becomes the default source
23	Set Input to "HDMI"	08 22 05 00 00 00 00 D1	set the input source to HDMI, which becomes the default source
24	Set Input to "VGA"	08 22 06 00 00 00 00 D0	Set the input source to VGA, which becomes the default source
25	Set Volume to "X" (0-100)	Set to 100: 08 22 09 00 00 00 64 69	Speaker volume set to commanded volume
26	Get Volume	04 21 0F CC	returns "Volume = value"
27	Set Mute to "on"	08 22 0A 00 00 00 01 CB	activates Mute, for no audio (note that this setting is not saved when hard power is turned off)

28	Set Mute to "off"	08 22 0A 00 00 00 00 CC	deactivates Mute
29	Get Mute	04 21 14 C7	If Mute has been changed by OSD commands, returns "Mute = value" where 0 is mute off and 1 is mute on; may not reflect actual Mute settings if Mute settings were changed by serial commands (known bug)
30	Get Input Status	04 21 07 D4	returns "HDMI", "VGA", or "DPRx" (if no source is present, returns the last source searched...so use the Get Power Status command to check for active source)
31	Set Color Space to full color	08 22 12 00 00 00 00 C4	color space set to full color
32	Set Color space to sRGB	08 22 13 00 00 00 02 C1	color space set to sRGB
33	Get Color Space	04 21 15 C6	returns "Color Space = value"
34	Do an Auto Adjust	08 22 07 00 00 00 00 CF	if VGA (analog) source is present, a sync/timing auto adjust is done
35	Do Auto Color Adjust	08 22 08 00 00 00 00 CE	if VGA source is present, a gray level auto adjust is done
36	Do a Reset	08 22 11 00 00 00 00 C5	restores all settings to their factory defaults
37	Get Blacklevel Brightness	04 21 17 C4	returns "Brightness = value", where value ranges from -350 to 350 (this scale is different from the 0-255 scale used in the OSD)
38	Set Blacklevel Brightness	Set to 50: 08 22 16 00 00 00 32 8E	sets the offset for the color range to allow adjustment of the definition of black (See HDMI Full Range commands)
39	Get Auto Scan Status	04 21 18 C3	returns "Auto Scan = value", where value is 1 (on) or 0 (off)
40	Set Auto Scan to "on"	08 22 17 00 00 00 01 BE	Sets Auto Scan on, where the source inputs will continually be checked for activity beginning with the default or selected source

41	Set Auto Scan to "off"	08 22 17 00 00 00 00 BF	Sets Auto Scan off, so that only the default or selected source can be active (thus suppressing the pop up search windows on the LCD)
42	Get HDMI Full Range	04 21 1A C1	returns "HDMI Full Range = value", where value is 1 (full range on) or 0 (limited range on) or 2 (user-selected contrast or brightness settings in effect, or input source is VGA)
43	Set HDMI Full Range to "on"	08 22 19 00 00 00 01 BC	sets the standard HDMI Full Range, where for each color the range is 0 for black and 255 for full brightness (white)--note that this impacts both HDMI and DisplayPort sources
44	Set HDMI Full Range to "off"	08 22 19 00 00 00 00 BD	sets HDMI Full Range to "limited range" (useful for maintaining good contrast with cinema-type sources) where for each color the range is 15 for black and 235 for full brightness (white)--note that this impacts both HDMI and DisplayPort sources

# SNMP Monitoring

The current settings and status of UltraLux units can be remotely monitored using SNMP (Simple Network Management Protocol), if the SNMP option is enabled through the web browser settings. The MIB (Management Information Base) used for all Planar display products is available by electronic distribution in the file **PLANAR-DISPLAY-MIB.txt**. The table below shows the objects that can be monitored – all Planar SNMP objects are read-only, and no traps are used. The default read-only community string for all Planar SNMP objects is “public”. Once the PLANAR-DISPLAY-MIB is loaded in your SNMP manager, you can walk all the available objects from the top-level object PlanarSystems(1.3.6.1.4.1.19125) or its sub-object PlanarDisplayProduct(1).

Most object values are integer type, except where noted. Generally, for integer types, the value -1 is returned if there is any internal system or communication error, and normal return values are zero or positive integers.

Object Name	Description	Value
plnrModel	Model name (string)	UltraLux
plnrInputSelect	User-selected input source	1 = HDMI, 2 = DisplayPort, 3 = VGA
plnrInputStatus	Input source status	0 = Source Absent, 1 = Source Present
plnrDisplayBacklight	Backlight on/off state	1 = On, 0 = Off
plnrDisplayBrightness	User-selected brightness value	0-100
plnrDisplayContrast	User-selected contrast value	0-100
plnrDisplaySharpness	User-selected sharpness value	0-8
plnrDisplayColorSpace	User-selected color space	0 = full color 2 = sRGB
plnrDisplayColorTemp	User-selected color temperature	2 = 4200K 3 = 5000K 4 = 6500K 5 = 7500K 6 = 9300K 7 = user
plnrDisplayGainRed	User-selected red gain value  <b>Note:</b> Gain values apply only when color temperature setting is 7 or user.	0-100
plnrDisplayGainGreen	User-selected green gain value	0-100
plnrDisplayGainBlue	User-selected blue gain value	0-100
plnrAudioVolume	User-selected volume setting	0-100
plnrAudioMute	User-selected audio mute	1 = On, 0 = Off
plnrPower1	Power supply #1 status	1 = OK, 0 = Failed
plnrPower2	Power supply #2 status	1 = OK, 0 = Failed

## Sending RS232 Commands Via UDP

The UDP port 57 accepts the same command sets as RS232. It is convenient for IP control applications and can be tested with a UDP terminal program such as the Hercules SETUP utility available from [www.HW-group.com](http://www.HW-group.com)

**Note:** Ensure that the **Enable ASCII command service (UDP port 57)** box is checked on the Access Control page of the Remote Monitoring software.

Notice the following in the example below:

- The Module IP address must match the Planar device server’s IP address
- Enter **57** in the **Port** box.
- “04 21 16 C5” in the **Send** box corresponds to the Get Power Status RS232 command.

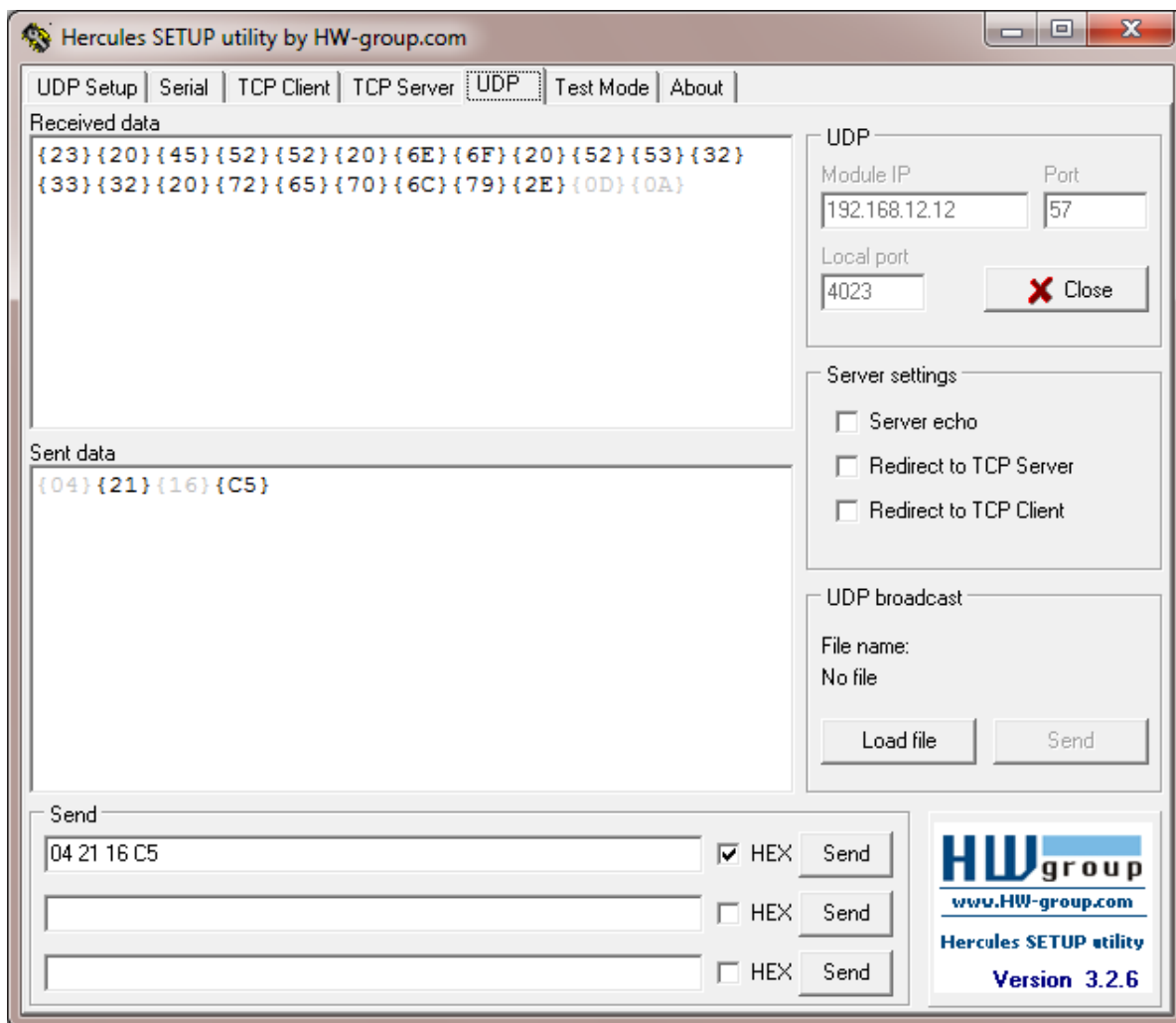



## Using WallNet Assistant

WallNet Assistant is a software program that finds Planar hardware on a network. This will help you find the IP address needed to access the Remote Monitoring functions.

- 1 WallNet Assistant is distributed as **Planar\_WallNet\_Assistant\_(version).zip**. Extract all files to a new folder in your "Program Files" folder (or another convenient location).

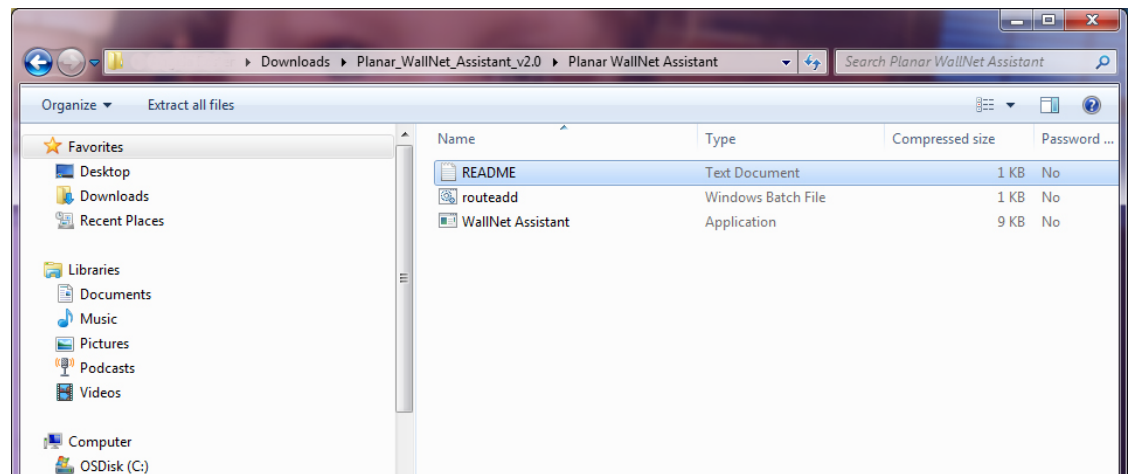

- 2 Double-click "WallNet Assistant.exe" to launch Planar WallNet Assistant. If any error messages appear, then download and install (or update) Microsoft .NET Framework version 2.0, and then try launching "WallNet Assistant.exe" again.

- 3 When WallNet Assistant starts, it looks for all Planar device servers on the network and lists them in the window.

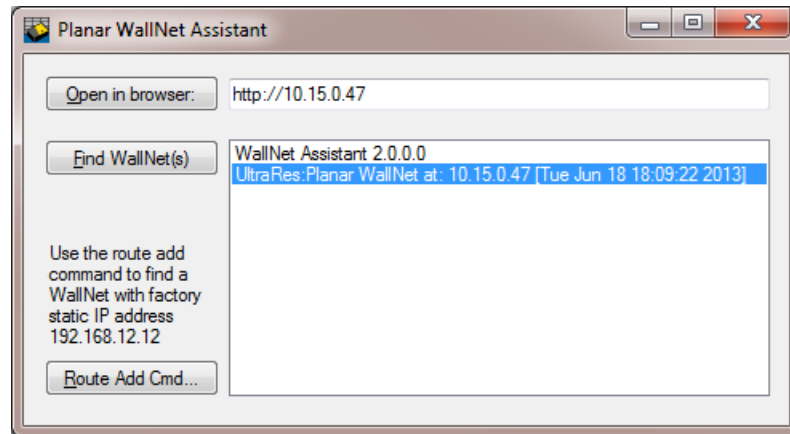

- Each Planar device found on the local network is listed with its name, IP address, date and time.
  - New device servers just out of the box are listed with default names. The date and time shown are from the device's own clock. Both of these can be changed later.
  - WallNet Assistant uses a very simple broadcast protocol to discover Planar device servers on the local network. Most networks do not route broadcast packets, so it is very possible to have properly configured, reachable devices on your network that WallNet Assistant won't find. Consult with your network administrator if you are having trouble using WallNet Assistant to find Planar devices. Also see the information about the Route Add Command at the end of this section if you are trying to find a device at the factory static IP address.
- 4 You can double-click any Planar device server in the list to open your default browser pointed at that device.

- 5 When your browser connects to a Planar network device, you should see a page similar to the following.

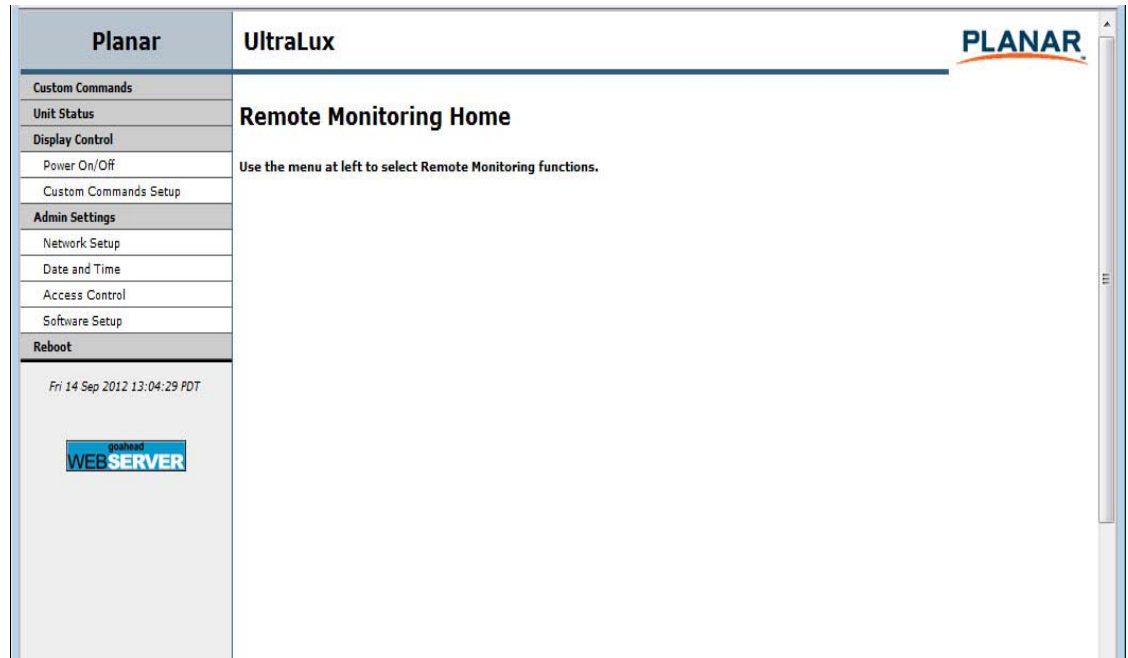

## Route Add Command

If you are trying to connect to a Planar device server that you believe is at the factory default IP address, and your computer is not on the 192.168.12.0 network, then you can use the route add command to establish a connection from your computer to that device server. This method only works if your computer and the Planar device are connected to the same network switch or hub.

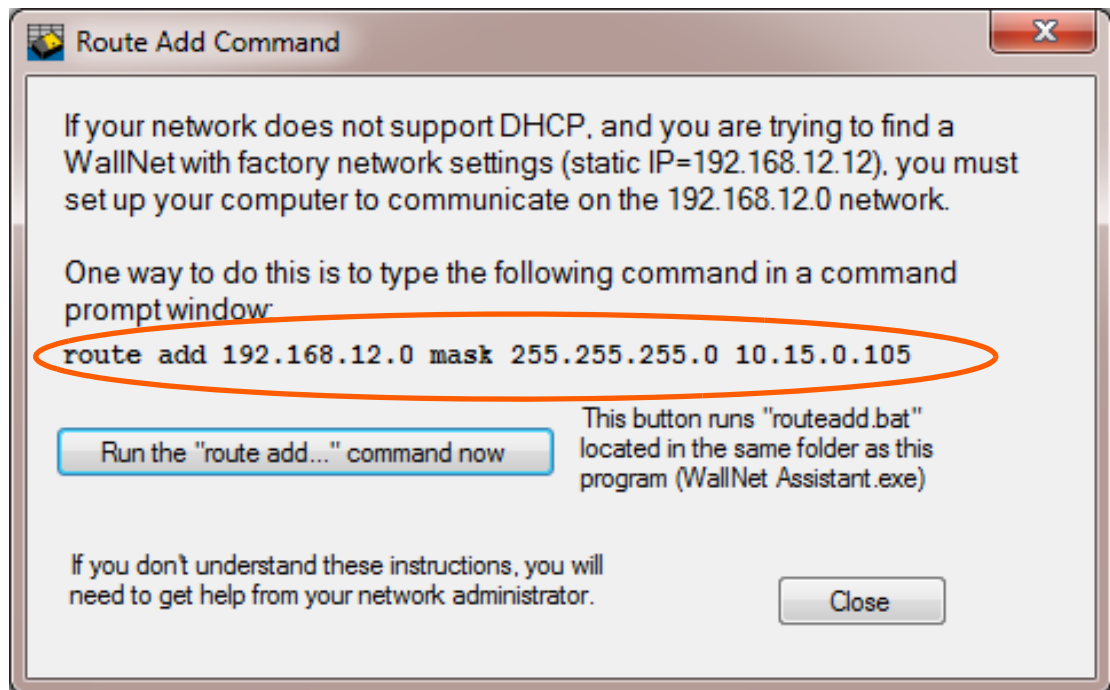

- 1 When you click the **Route Add Cmd** button, the route add command window (shown above) opens.
- 2 The area circled in the example above shows the syntax of the route add command. The final IP address on the command line must be the IP address of your computer's network interface that is connected to the same hub/switch as the Planar device.
- 3 You can either type this command into a command prompt or click the **Run the "route add..." command now** button to launch the routeadd.bat script, which will run the command exactly as shown.
- 4 When the route add is successful, it establishes a temporary network route from your computer to the 192.168.12.0 network. This allows your computer to communicate with the Planar device server located at 192.168.12.12.

# Planar UltraLux Remote Monitoring

Planar UltraLux Remote Monitoring is software that displays information about the LCD display via a web browser. It is used primarily for monitoring, reporting and some control (for example, powering the displays on and off either manually or per a pre-defined schedule).

## Remote Monitoring Home

This is the first page you will see when you open the Planar UltraLux Remote Monitoring software. Launch a web browser. If you are using DHCP, enter in the IP address shown on the Info tab of UltraLux Remote Monitoring. If you are not using DHCP, enter <http://192.168.12.12> in the address bar. For either web address entered, you should see a page similar to the following.

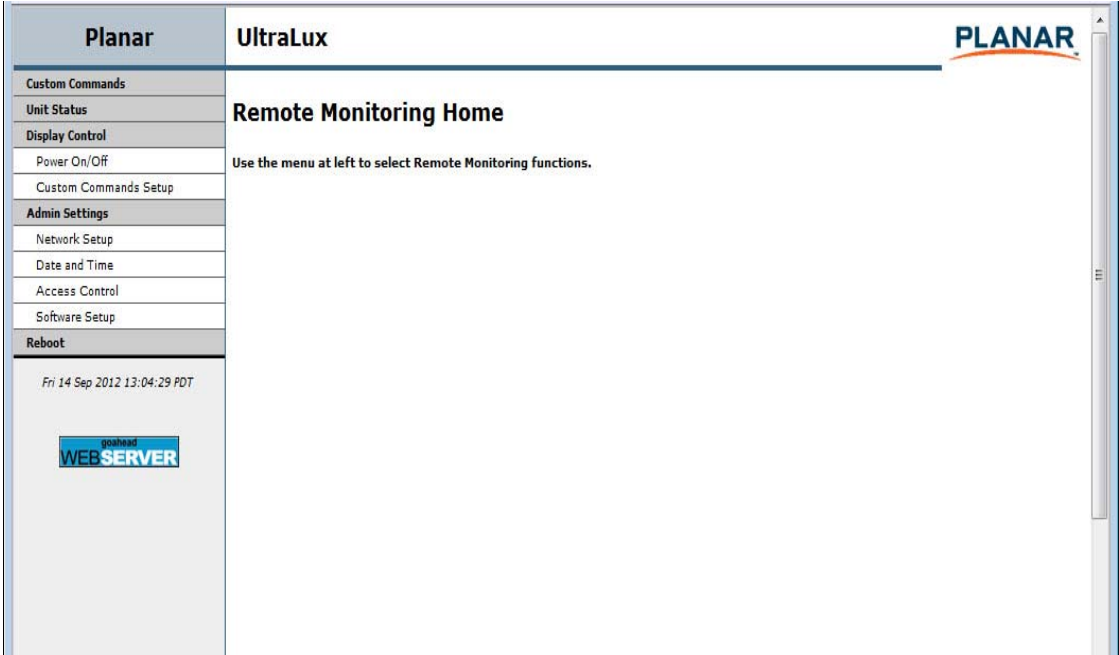

## Unit Status

The Unit Status page shows a list of the different system settings for the LCD. It also shows whether or not the two power supplies contained in the control module are on or off.

The screenshot displays the Planar UltraLux remote monitoring interface. The top header includes the 'Planar' logo on the left and the 'UltraLux' model name on the right, with the 'PLANAR' logo in the top right corner. A left-hand navigation menu lists several categories: Custom Commands, Unit Status (which is currently selected), Display Control, Admin Settings, and Reboot. Under 'Unit Status', a list of system settings is displayed, including Backlight, Brightness, Input Select, Input Status, Power Supply 1, Power Supply 2, Color Space, ColorTemp, Red Gain, Green Gain, Blue Gain, Contrast, Sharpness, Volume, and Mute. At the bottom of the page, the date and time are shown as 'Fri 14 Sep 2012 13:11:40 PDT'.

Planar	UltraLux
Custom Commands	
Unit Status	<b>Unit Status</b>
Display Control	
Power On/Off	
Custom Commands Setup	
Admin Settings	
Network Setup	
Date and Time	
Access Control	
Software Setup	
Reboot	
Fri 14 Sep 2012 13:11:40 PDT	

Backlight: Off  
Brightness: 50  
Input Select: HDMI  
Input Status: Absent  
Power Supply 1: OK  
Power Supply 2: Fail  
Color Space: Full  
ColorTemp: 6500K  
Red Gain: 100  
Green Gain: 100  
Blue Gain: 100  
Contrast: 50  
Sharpness: 4  
Volume: 20  
Mute: On

## Display Control

The Display Control page contains two sub-pages: Power On/Off and Custom Commands Setup. These are described in the following pages.

Planar	UltraLux
<ul style="list-style-type: none"> <li>Custom Commands</li> <li>Unit Status</li> <li>Display Control</li> <li>Power On/Off</li> <li>Custom Commands Setup</li> <li>Admin Settings</li> <li>Network Setup</li> <li>Date and Time</li> <li>Access Control</li> <li>Software Setup</li> <li>Reboot</li> </ul>	<div style="text-align: right;"></div> <h3>Display Control</h3> <p><b>NOTE:</b> The display control functions require 'operator' level access.</p> <hr/> <h4>Power On/Off</h4> <p>Interactively control display power, and schedule automatic power on and off.</p> <hr/> <h4>Custom Commands Setup</h4> <p>Configure custom programmed buttons to send RS232 ASCII commands and view display responses.</p> <p><i>Fri 14 Sep 2012 13:13:13 PDT</i></p>

## Power On/Off

Power On/Off buttons control the backlight power, not the AC power. You cannot control AC power through Planar UltraLux Remote Monitoring.

This section has four options for which you can schedule an automatic power on/off. The options are: no automatic power on/off, same daily schedule, Monday-Friday same schedule and weekends off. Or each day has its own schedule. You can only select one of the schedule types. The default is No automatic power on/off.

**Planar**

---

Custom Commands

Unit Status

Display Control

• Power On/Off

Custom Commands Setup

Admin Settings

Network Setup

Date and Time

Access Control

Software Setup

Reboot

Fri 14 Sep 2012 13:14:36 PDT

**UltraLux**

---

### Power On/Off

**Power:**    On    On    Off

**Schedule Automatic Power On / Off**

No automatic power on / off

Every day has the same schedule

On at:  Enter times in 24-hour clock, e.g. 1400 = 2pm

Off at:

Monday-Friday have the same schedule, weekends off

On at:  Enter times in 24-hour clock, e.g. 1400 = 2pm

Off at:

Each day has its own schedule

Enter times in 24-hour clock, e.g. 1400 = 2pm

<b>MONDAY</b>	On at: <input type="text"/>	Off at: <input type="text"/>	
<b>TUESDAY</b>	On at: <input type="text"/>	Off at: <input type="text"/>	
<b>WEDNESDAY</b>	On at: <input type="text"/>	Off at: <input type="text"/>	
<b>THURSDAY</b>	On at: <input type="text"/>	Off at: <input type="text"/>	
<b>FRIDAY</b>	On at: <input type="text"/>	Off at: <input type="text"/>	
<b>SATURDAY</b>	On at: <input type="text"/>	Off at: <input type="text"/>	
<b>SUNDAY</b>	On at: <input type="text"/>	Off at: <input type="text"/>	

**Submit Changed Settings**

Click to change settings:

Change Power On/Off Settings



## Custom Commands Setup

The Custom Commands Setup page allows you to establish what the ten Custom Command buttons will do.

- 1 Type a label for the button in **Button 1 Text**.
- 2 In **ASCII Command(s)**, enter a binary protocol such as hex commands. An example is shown above.
- 3 Click **Test button 1 commands** to send the commands immediately. You will see an output page showing the commands sent and replies received (if any). Use the browser's **Back** button to return from this results page to avoid losing unsaved changes. If you select the Custom Commands Setup page again, you will lose unsaved changes.
- 4 Scroll to the bottom of the Custom Commands Setup page and click **Change Custom Command Buttons**. This applies what you have done to the custom buttons accessed from Custom Commands Setup at the top of the left menu.

**Note:** It is suggested that you only send one command at a time. If you want to send additional commands, repeat the steps in this section.

## Admin Setup

The Admin Setup page contains three sub-pages: Network Setup, Time and Date, Access Control and Software Update. These are described in the following pages.

Planar	UltraLux
Custom Commands	
Unit Status	<b>Admin Settings</b>
Display Control	
Power On/Off	<b>Network Setup</b>
Custom Commands Setup	Specify network settings (such as DHCP vs. static IP address assignment) and specify server names or addresses for email and time services.
<b>Admin Settings</b>	
Network Setup	
Date and Time	<b>Date and Time</b>
Access Control	Manually set date and time, optionally specify a network time server, set timezone.
Software Setup	
<b>Reboot</b>	<b>Access Control</b>
	Enable or disable network and serial console access.
	<b>Software Update</b>
	Load software updates, reset to factory settings.
Fri 14 Sep 2012 13:18:24 PDT	

## Network Setup

This page allows you to configure network settings and whether or not you use DHCP.

The screenshot shows the 'Network Setup' page for a Planar UltraLux device. The left sidebar contains navigation options: Custom Commands, Unit Status, Display Control, Power On/Off, Custom Commands Setup, Admin Settings (with sub-items: Network Setup, Date and Time, Access Control, Software Setup), and Reboot. The main content area is titled 'Network Setup' and includes the following sections:

- Hostname and Domain Name:** Explains that the hostname is used for identifying a unit and is limited to 16 alphanumeric, dash, or underscore characters. The 'Hostname' field is set to 'Planar'. The 'Domain name' field is empty.
- DHCP:** States that a DHCP server must be configured for automatic setup. The 'Use DHCP for automatic network settings' section has 'Yes, use DHCP' selected. The 'DHCP timeout in seconds' is set to 5.
- Static (non-DHCP) Network Settings:** Lists two cases where static settings are used: DHCP is not enabled or a DHCP server does not respond. It provides fields for IP address (10.15.0.202), Network mask (255.255.255.0), DNS server 1, DNS server 2, and Gateway (10.15.0.1).
- Apply Changes:** A button labeled 'Confirm and apply new network settings' is present at the bottom.

- 1 In the **Hostname** box it now says Planar. Change this name to something more appropriate. This will be the name for this particular server. The hostname is limited to 16 characters: alphanumeric, dash, or underscore only.
- 2 If you want to enter a domain name for server name lookups, type it in the **Domain name** box.
- 3 Do one of the following:
  - If you will use DHCP, go to step 4.
  - If you will **not** use DHSCP, go to step 5.
- 4 Under the DHCP section, choose **Yes, use DHCP**.
  - a Change the default DHCP timeout (ten seconds) only if instructed by your network administrator.

- b You do not need to fill in anything under the Static (non-DHCP) Network Settings section. However, if you do, these settings will be used in the event that the DHCP attempts to time out.
  - c Go to step **6**.
- 5** Under the DHCP section, choose **No, use static settings**.
- a In the Static (non-DHCP) Network Settings section, enter the **IP address** given to you by the network administrator.
  - b Enter the **Network mask, DNS server(s), and Gateway** as instructed by the network administrator.
  - c Go to step **6**.
- 6** Scroll to the bottom of the page and click **Confirm and apply new network settings** to receive the Confirm Network Change page.
- 7** Review the settings to make sure they are correct. Click **OK, apply changes now** to receive the Applying Network Changes page. This shows the network settings to be used.
- Note:** If you have changed the static IP address or changed from static to DHCP setup, you may need to point your browser at the new address.
- 8** You may have to click the **Refresh** button on your browser to see the new name in the upper left corner of the page.

## Date and Time

Use this page to change date and time information as needed.

**Planar UltraLux** **PLANAR**

**Custom Commands**

**Unit Status**

**Display Control**

Power On/Off

Custom Commands Setup

**Admin Settings**

Network Setup

**Date and Time**

Access Control

Software Setup

**Reboot**

Fri 14 Sep 2012 13:43:05 PDT

---

**Date and Time**

Using an NTP server to automatically set date and time is not required, but is recommended. You should use a locally maintained NTP server if possible, otherwise search for a public time server near you that allows general access. The availability of public time servers is a courtesy provided by their administrator: please honor the access policy of any server you use.

If you choose to only manually set the time and date, you will need to reset the correct time and date whenever the Planar device loses power (there is no battery backup).

You should always set the correct timezone information. To operate in Universal time (UTC, formerly GMT), you can leave the timezone blank.

---

**Date and Time Server**

NTP server name or address:  
216.228.192.69

Poll interval in minutes (min=5, max=1440):  
60

Apply Changes:  
[Click here to apply server and interval settings changed above.](#)

---

**Manual Date and Time**

Enter local time and date as MM/DD hh:mm YYYY (12 digits required, use 24-hour clock).

Manually set date and time:  
*Spaces and punctuation are ignored: 090514552002 is also OK. There must be 12 digits in correct order.*

09/14 13:43 2012

---

**Local Time Zone**

Format is: XST offset XDT offset, Mmm.wk.dow, Mmm.wk.dow  
For example: PST+8 PDT+7, M3.2.0, M11.1.0 specifies U.S. Pacific time (as of 2007).

The abbreviations for standard and daylight saving times must be at least 3 characters.  
Use -offset for time zones west of GMT, +offset for time zones east of GMT.

If your locale does not observe daylight saving, omit everything after the first offset.  
For example, EST+5 is correct for most of Indiana, which stays on U.S. Eastern Standard time all year.

The first Mmm.wk.dow gives the month, week, and day of week that starts daylight saving.  
The second Mmm.wk.dow gives the month, week, and day of week that ends daylight saving.  
Ranges are mm=1-12 wk=1-5 dow=0-6 where 0=Sunday. The time change occurs at 0200 local time.

The start and end of daylight saving default to first Sunday of April and last Sunday of October.  
**NOTE:** As of 2007, U.S. locales which observe daylight saving time must enter start and end dates.  
For example, EST5EDT,M3.2.0,M11.1.0 is correct for U.S. Eastern time zone as of 2007.

Specify local time zone:  
*You may enter spaces for convenience but they are ignored in the input.  
The instructions above are not exhaustive. Any valid value for Linux TZ environment variable is correct.*

PST+8PDT+7,M3.2.0,M11.1.0

- 1 Set the date and time manually in the box under the Manual Date and Time section. The date format is very exact. Fill in the current date and time using exactly the format shown on the page. Click **Set date and time**.
- 2 If you want to have the server periodically check the time from a network source, fill in the NTP server name or address, and poll interval in the Date and Time Server section. Click **Apply new date and time server settings**.

**Note:** If you don't have a preferred NTP server, then [www.pool.ntp.org](http://www.pool.ntp.org) is a reasonable choice for most installations.

- 3 Carefully read the instructions in the Local Time Zone section. Fill in the text box and click **Set time zone**.

**Note:** The start and end of daylight saving time default to the first Sunday of April and the last Sunday of October. As of 2007, U.S. locales that observe daylight saving time must enter start and end dates in this section. For example, EST5EDT,M3.2.0,M11.1.0 is correct for U.S. Eastern time zone as of 2007.

## Access Control

The Access Control page allows you to set parameters needed to access the web, the Remote Monitoring network, RS232 commands, as well as select the correct baud rate.

**Planar UltraLux** **PLANAR**

**Access Control**

**Web Access**

Password protection is an optional feature to restrict access to the system.  
 NOTE: After passwords are set, the number of characters shown in the input boxes below does not reflect the actual length of the password, but is just an indicator that there is a password set.

Admin password:  Confirm:  [Set admin password](#)

**Network Access**

The daytime service is used by the Remote Monitoring Assistant program to locate Remote Monitoring systems on the local network. If you assign static IP addresses, or use another way to locate Remote Monitoring on your network, you may not need the daytime service.

Enable daytime service (UDP port 13)

The ASCII command service enables custom programs to send ASCII commands to, and receive replies from, the displays connected through this Remote Monitoring software. You should leave the ASCII command service disabled unless you know it is required.

Enable ASCII command service (UDP port 37)

Telnet login may be needed for occasional Remote Monitoring administration, but is not required for normal Remote Monitoring setup and operation. You should leave telnet login disabled unless you know it is required.

Enable telnet login

[Change network access](#)

**RS232 Access**

**Select Serial Service**

Serial Command Service is for normal operation.  
 Maintenance Console is for engineering use.  
 Disabled is for reduced functionality.

Serial Command  
 Maintenance Console  
 Disabled

**Select Baud Rate**

Select the baud rate that matches the host setup:

9600  19200

[Change RS232 Settings](#)

*Fri 14 Sep 2012 13:44:01 PDT*

## Software Setup

This page allows you to upload the latest UltraLux Remote Monitoring software. You can also reset all of your settings to the factory defaults, as well as choose the web page link that is associated with the Planar logo in the top right corner of the page.

**Planar** UltraLux **PLANAR**

**Software Setup**

**Software Update**

Current Version: Pre-release 2012-08-29 for UltraLux

Click Browse to select software image file to load:

After browsing to select software image file, click here to load:

The original Remote Monitoring software that came with your hardware is located on the distribution media. Updated Remote Monitoring software is made available for download from the [Planar website](#). If you download new software, first save it to a local drive, then browse to locate and load it using the instructions below.

To load new Remote Monitoring software:

1. You must know the location of the new software image file that you wish to load.
2. Click the Browse button to locate the software image file to load.
3. Click the Load Software button to load the software.

The load process can take a few minutes depending on the speed of your network. It is **very important** that once the load process begins it is not interrupted. If you have difficulty, see the user manual for more instructions.

**Reset to Factory Default**

Clicking the button below resets ALL settings to the factory default. This includes network settings, date and time, etc. as well as settings like scheduled power on/off and other setup options.

Click here to reset software options to factory default:

**Product ID Link**

You can change the link at the top center of every web page, to point to any web page you choose. To return to the default setting just delete any custom setting here.

Product ID Link:

Click here to modify the product ID link:

**Advanced Settings**

In normal operation, Remote Monitoring uses system queries on a regular basis to monitor each display for source sync status and to verify the display is responding to RS232 commands, as well as to check for any configured alert conditions such as power supply status. Selecting this option disables activity generated by this background polling.

**NOTE: This is for diagnostic use only. This setting is NOT saved. Selecting this option disables all alerts.**

Disable polling for alert conditions.

- 1 Click the **Choose File** button to locate the latest UltraLux software that you downloaded from Planar's website.

**Note:** Make sure the software is downloaded to a local drive.

- 2 Click the **Load Software** button to load the new software. This process can take a few minutes, depending on the speed of the network update. It is **very important** that you do not interrupt the load process once it begins.
- 3 If you want to reset **ALL** settings to the factory default, click the **Reset ALL to Factory Default** button. This includes network settings, date and time, etc., as well as display settings.

**Caution:** Using this option will reset all of your configurations and reboot the remote monitor. Because this includes network settings, be aware that the UltraLux Remote Monitoring software may not configure to the same network address after the system reboots.

- 4 When you click **Reset ALL to Factory Default**, you receive the Confirm Factory Reset page. Click **OK, Reset to Factory Defaults and Reboot** if you are sure you want to reset ALL settings to the factory default.
- 5 The top of each page shows the Planar logo, which is a link to <http://www.planar.com>. You can change this link to refer to any URL that you find useful by typing it into the **Product ID Link** box.
- 6 To make this link live, click **Change Product ID Link**.
- 7 In normal operations, Remote Monitoring polls the displays at a rate of one per second to look for user requests that have been made using the IR remote control and the on-screen menus. In some situations, this polling can have a noticeable performance impact. If you want to disable this polling, select the **Disable polling for alert conditions** checkbox. When you are finished, click **Change Advanced Settings**.

## Reboot

Click **Reboot now** to reboot your system. This copies everything in flash memory to RAM. RAM memory is used for all current operations. When power is applied to Remote monitoring, flash memory is copied to RAM. Reboot takes about 90 seconds.

Planar	UltraLux	PLANAR
Custom Commands	<b>Reboot</b>	
Unit Status	<b>System Uptime</b>	
Display Control	13:41:46 up 22:29, load average: 0.00, 0.00, 0.00	
Power On/Off	<b>Confirm Reboot</b>	
Custom Commands Setup	Reboot to revert to previously saved configuration settings, or to test newly saved settings.	
Admin Settings	<input type="button" value="Reboot now"/>	
Network Setup	Fri 14 Sep 2012 13:41:46 PDT	
Date and Time		
Access Control		
Software Setup		
Reboot		



## On-Screen Display Menus

On-screen menus can be accessed using the remote control. These menus allow you to adjust image brightness, contrast, sharpness, color, sound, and various System Settings. Below are pictures of the menus and a menu tree that shows the options on each menu.

## Image Menu



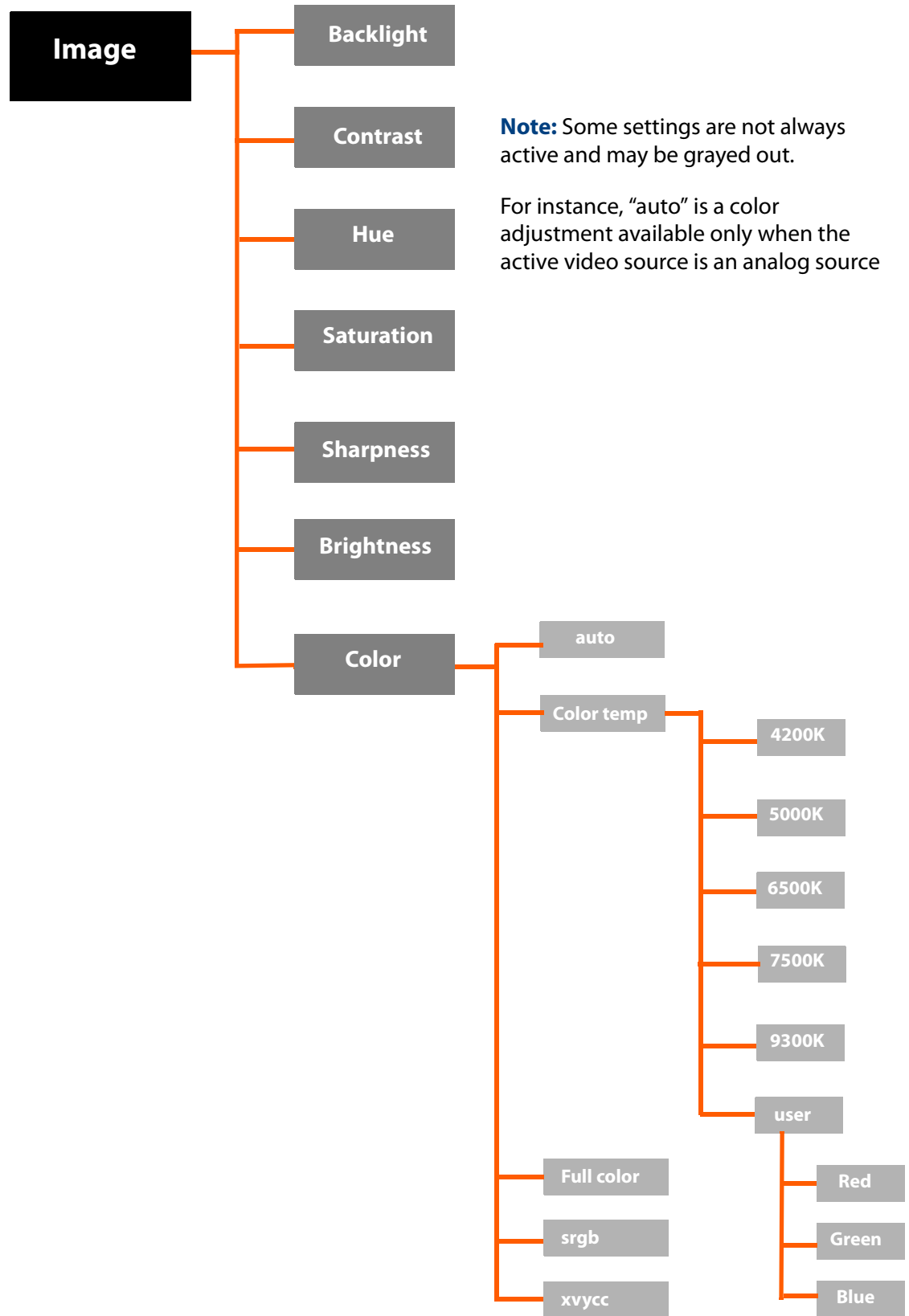

## Display Menu

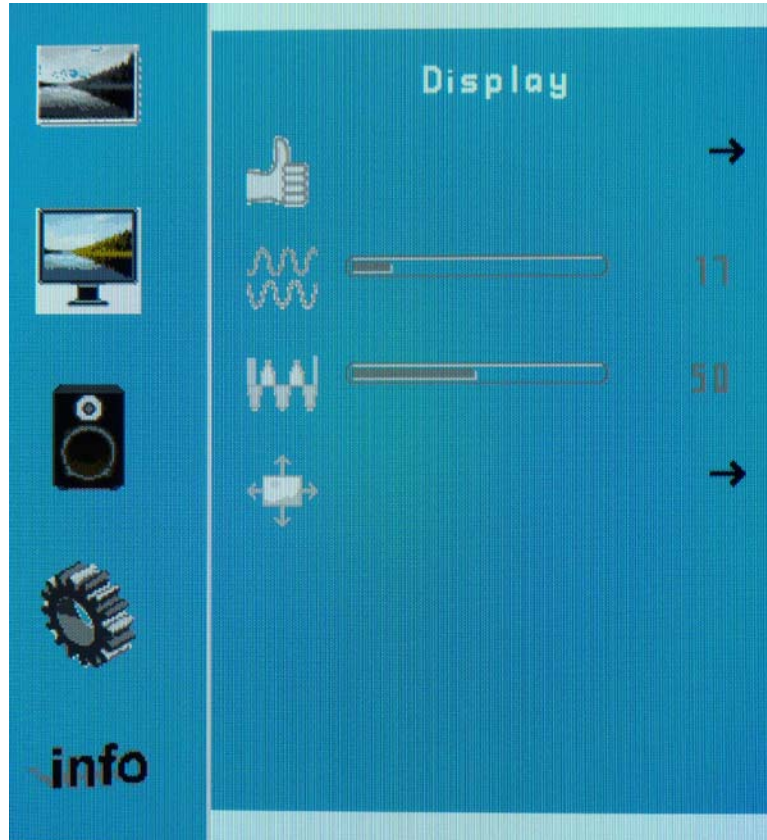

**Note:** The Display Menu is active only for analog video sources.

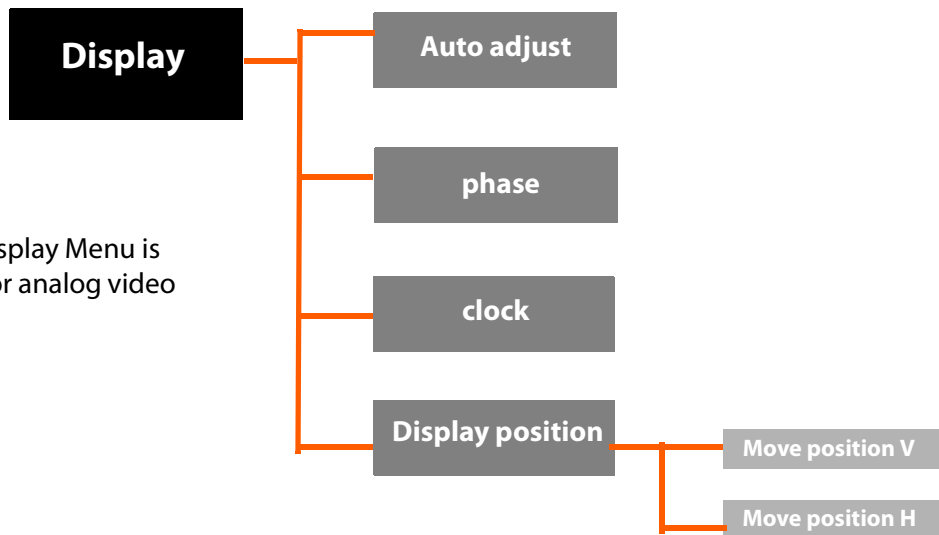

## Sound Menu

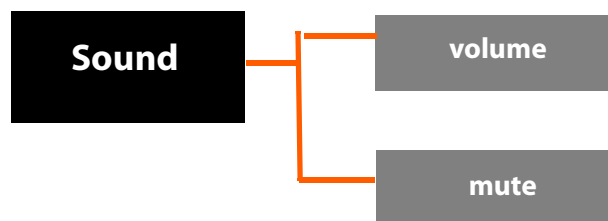
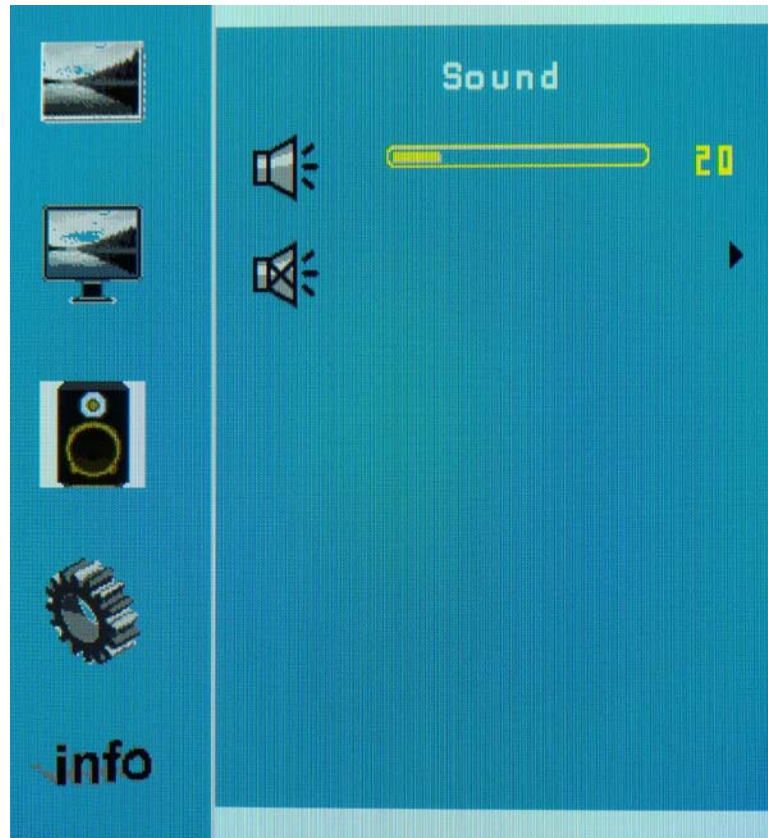

**Note:** For Mute, a caret > indicates Mute is off (which means sound is on). A power symbol  means the mute is on. Use the left and right arrow keys on the remote to adjust.

## System Menu



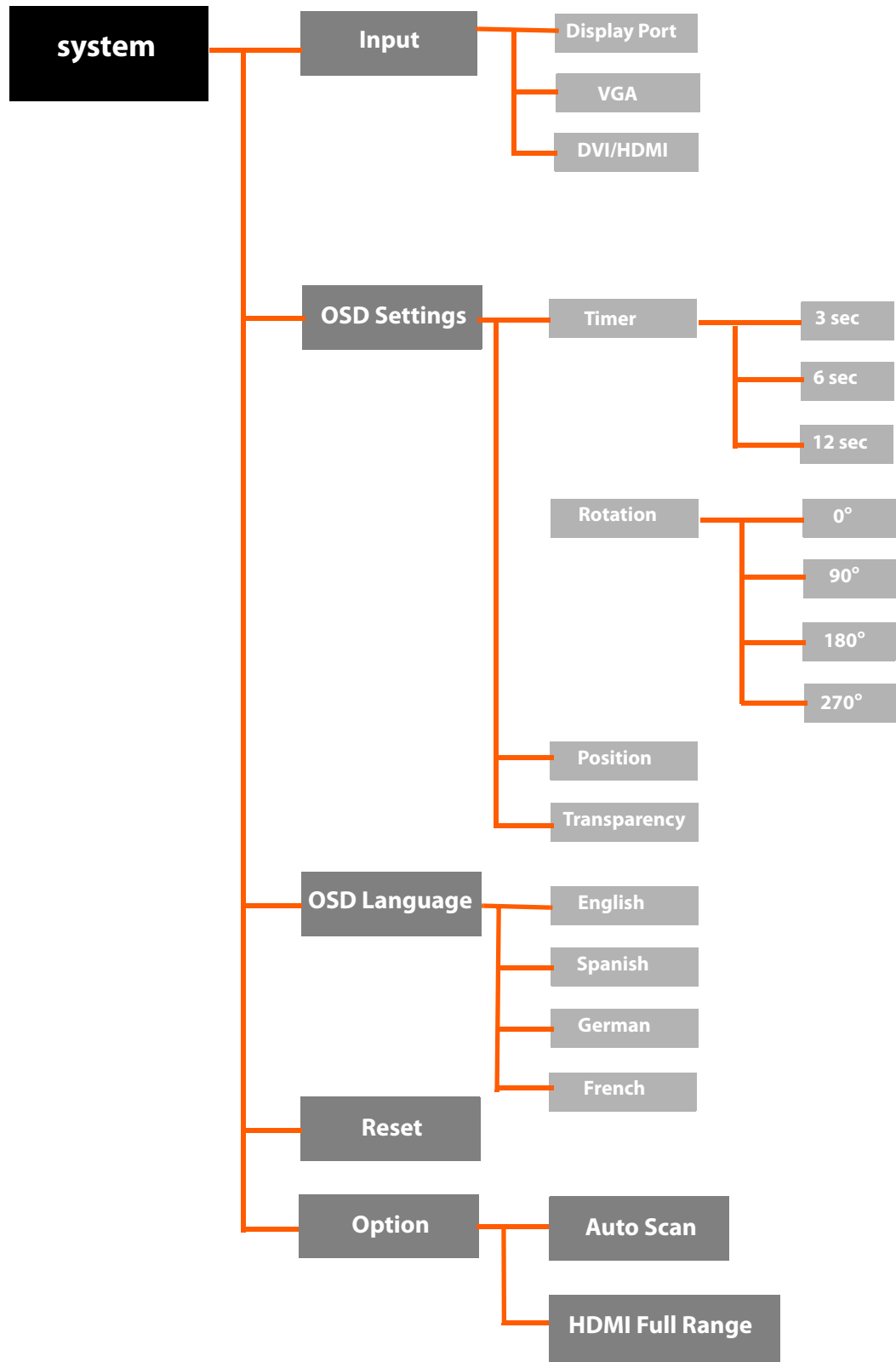

# Specifications

	<b>UltraLux 70"</b>	<b>UltraLux 80"</b>	<b>UltraLux 70" Touch</b>	<b>UltraLux 80" Touch</b>
Screen Active Area Size	70 inch	80 inch	70 inch	80 inch
Power Consumption (typical)	230W	350W	230W	350W
Dimensions (including mount)	62.2" x 36.2" x 3.2" (1581mm x 920mm x 80mm)	72.2" x 41.7" x 3.2" (1835mm x 1060mm x 80mm)	62.5" x 36.4" x 3.6" (1588mm x 926mm x 91mm)	72.4" x 41.9" x 3.6" (1840mm x 1065mm x 91mm)
Bezel Width	1.0" (24mm)	1.2" (29mm)	1.1" (28mm)	1.4" (34mm)
Weight	Standard: 133 lbs (60 kg) With ERO: 164 lbs (74 kg)	Standard: 174 lbs (79 kg) With ERO: 210 lbs (95 kg)	171 lbs (78 kg)	219 lbs (99 kg)
Mounting	Planar Profile mounting or VESA: 400x400; 4 holes	Planar Profile mounting or VESA: 600x600; 4 holes	Planar Profile mounting or VESA: 400x400; 4 holes	Planar Profile mounting or VESA: 600x600; 4 holes
Orientation	Portrait/Landscape			
Recommended Usage	24/7			
Aspect Ratio	16:9			
Brightness (typical)	700 nits			
Backlight	Edge-lit LED			
Contrast Ratio (typical)	5000:1			
Response Time (typical)	4 ms			
Frame Rate	120 Hz			
Viewing Angle	176° H,V			
Native Resolution	FHD 1920 x 1080 (1080p)			
Display Colors	> 1 billion, full 10-bit data path			
Surface Treatment	Optional ERO™ Optically Bonded Glass		ERO™ Optically Bonded Glass	
Control and Monitoring	RS232/LAN with SNMP			
Line Voltage	Universal 120/240V, 50/60Hz			
External Connections	HDMI, DisplayPort, VGA, AC Power IEC C14			
Operating Temperature	32°F to + 104°F (0°C to + 40°C)			
Storage Temperature	-4°F to + 140°F (-20°C to + 60°C)			
Humidity	20 to 90% RH			
Approvals	FCC Class A, EN60950, CE			
Options	Landscape wall mount, Portrait wall mount, 6-point multi-touch			
Warranty	3 Years Advanced Exchange			



## Signal Compatibility

The UltraLux Series supports the following factory preset modes:

<b>Mode</b>	<b>Resolution</b>	<b>Refresh Rate</b>	<b>Horizontal Frequency</b>	<b>Pixel Frequency</b>
VGA	640 x 480	60 Hz	31.5 kHz	25.157 MHz
SVGA	800 x 600	56 Hz	35.2 kHz	36 MHz
SVGA	800 x 600	60 Hz	37.9 kHz	40 MHz
XGA	1024 x 768	60 Hz	48.4 kHz	65 MHz
WXGA	1280 x 720	60 Hz	45 kHz	74.25 MHz
SXGA	1280 x 1024	60 Hz	64 kHz	108 MHz
UXGA	1600 x 1200	60 Hz	75 kHz	162 MHz
WUXGA	1920 x 1080	50 Hz	56.25 kHz	148.5 MHz
WUXGA	1920 x 1080	60 Hz	67.5 kHz	148.5 MHz

# UltraLux Dimensions

## 70" Display Dimensions - Front and Side Views

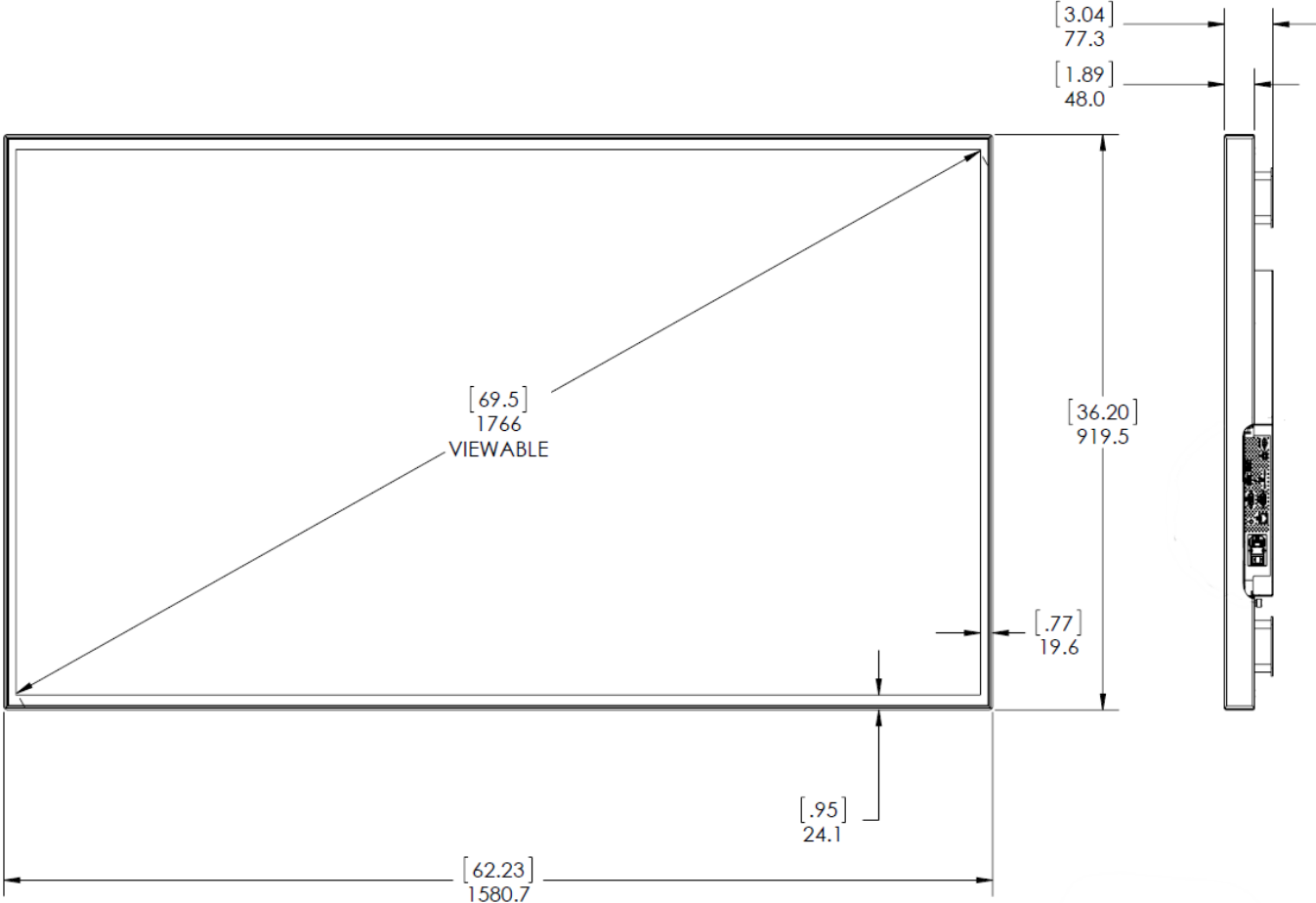

# 70" Display Dimensions - Rear View

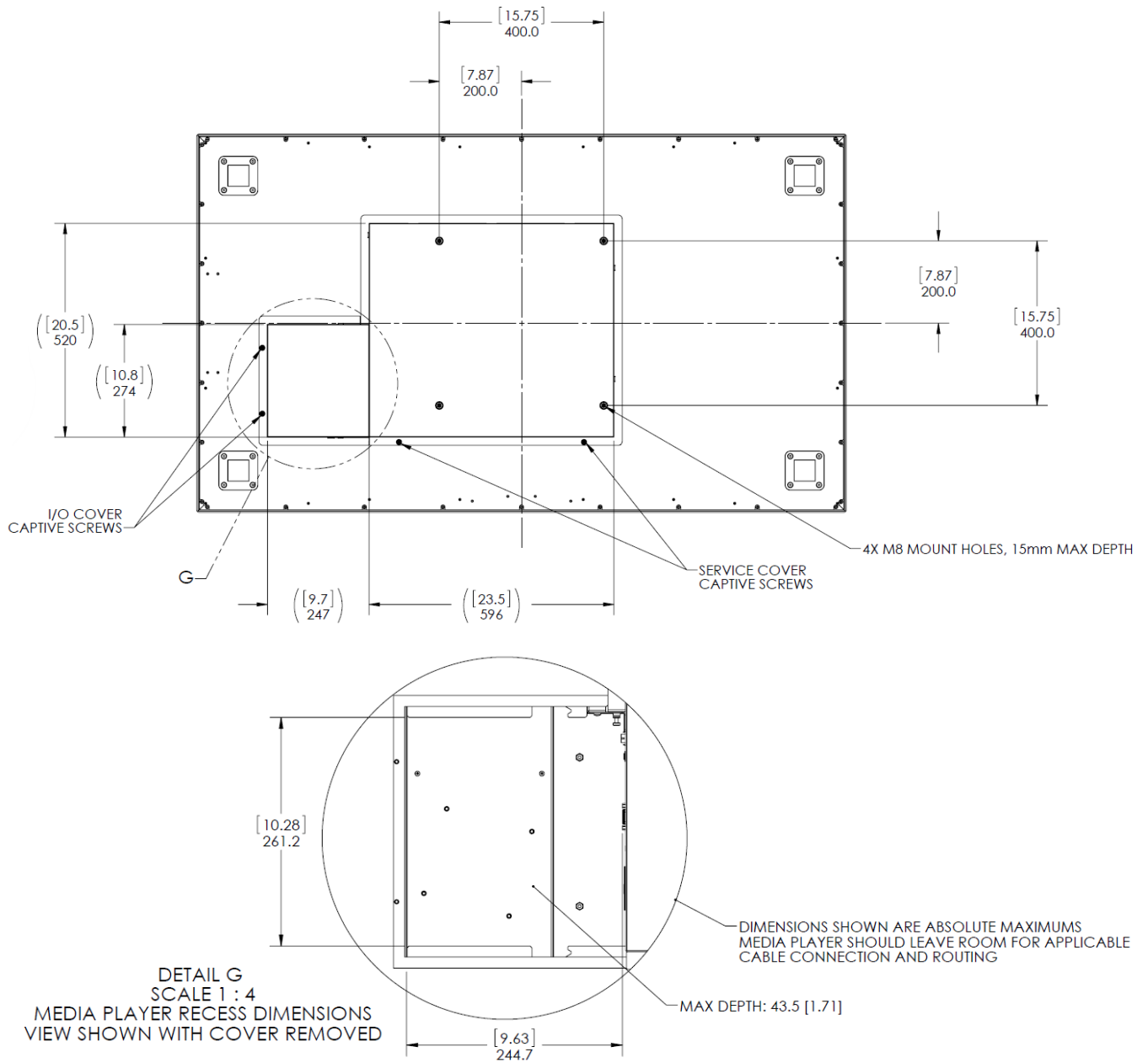



# 70" Landscape Wall Mounts - Front and Bottom Views

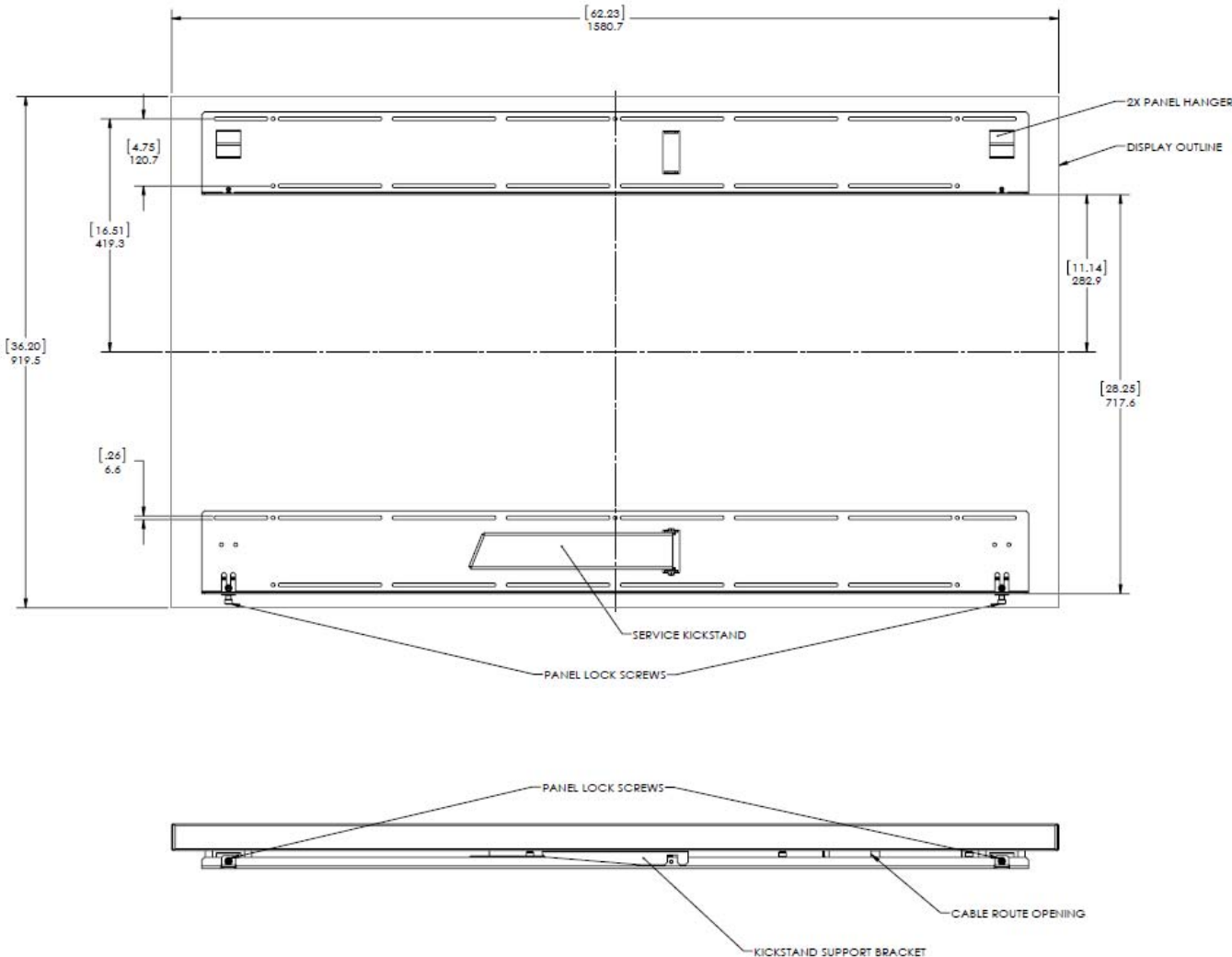

**Note:** Shown from the bottom of the panel.

# 70" Landscape Wall Mounts - Side Views

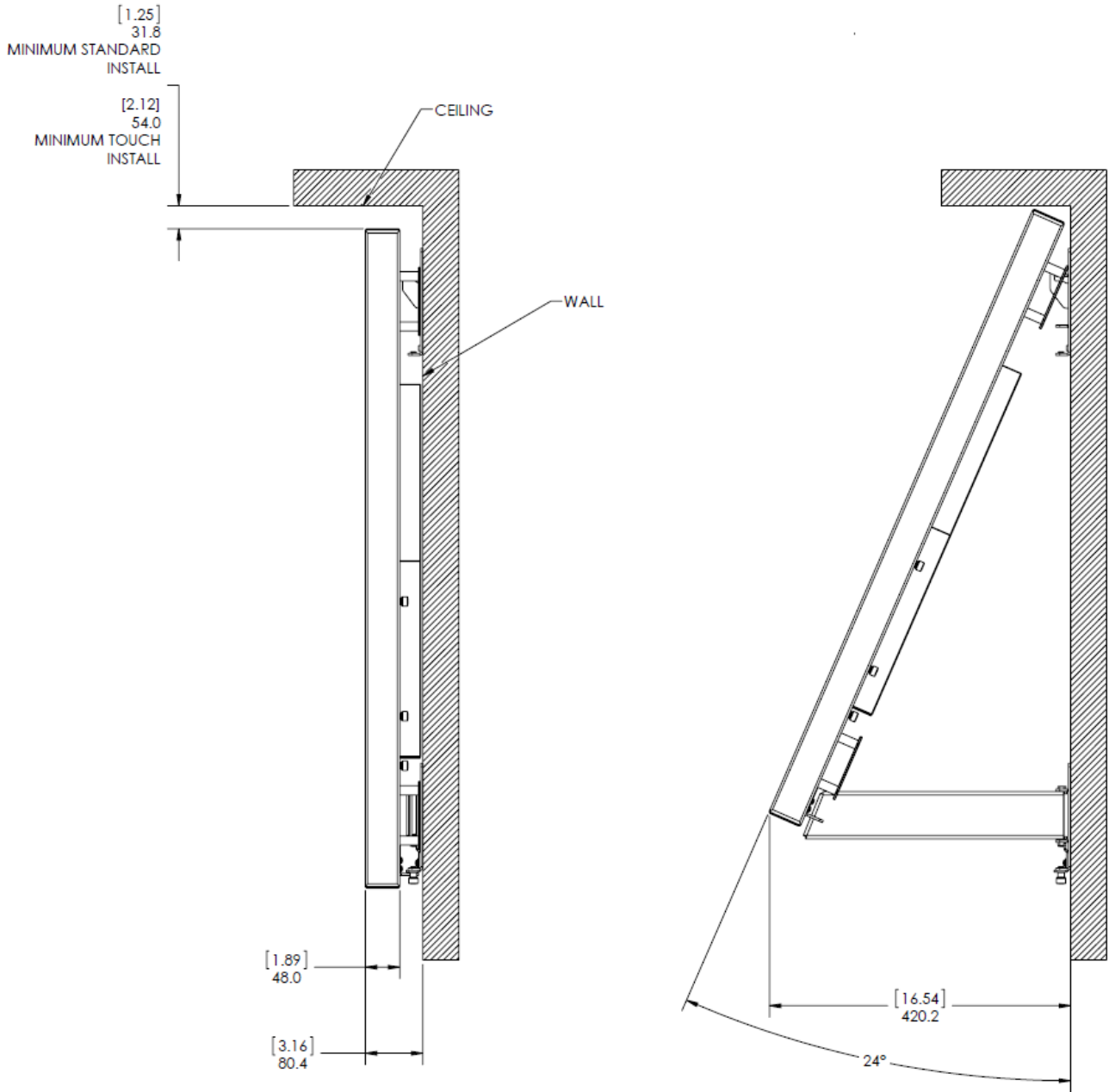

# 70" Portrait Wall Mounts - Front View

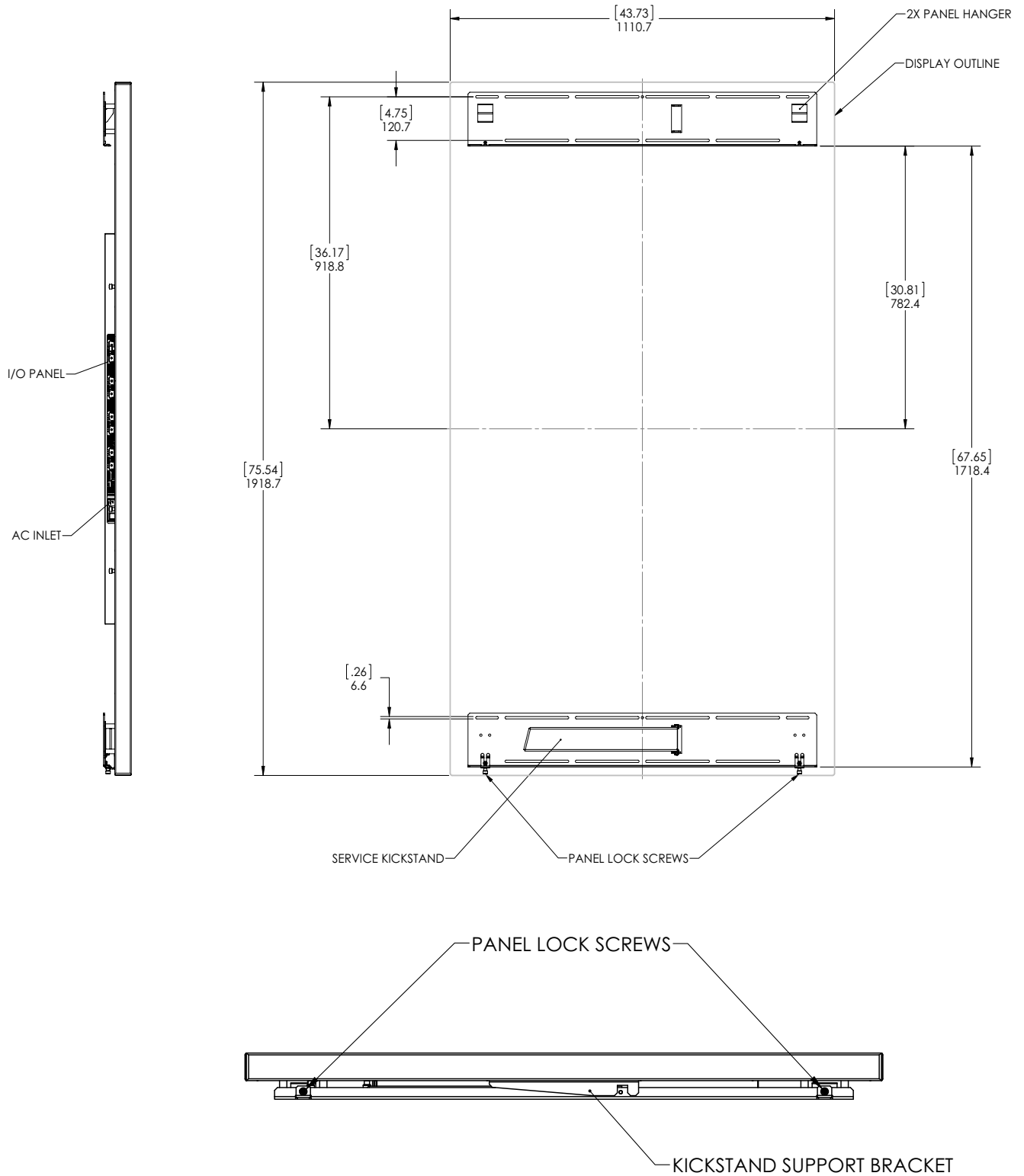

**Note:** Shown from the bottom of the panel.

# 70" Portrait Wall Mounts - Side Views

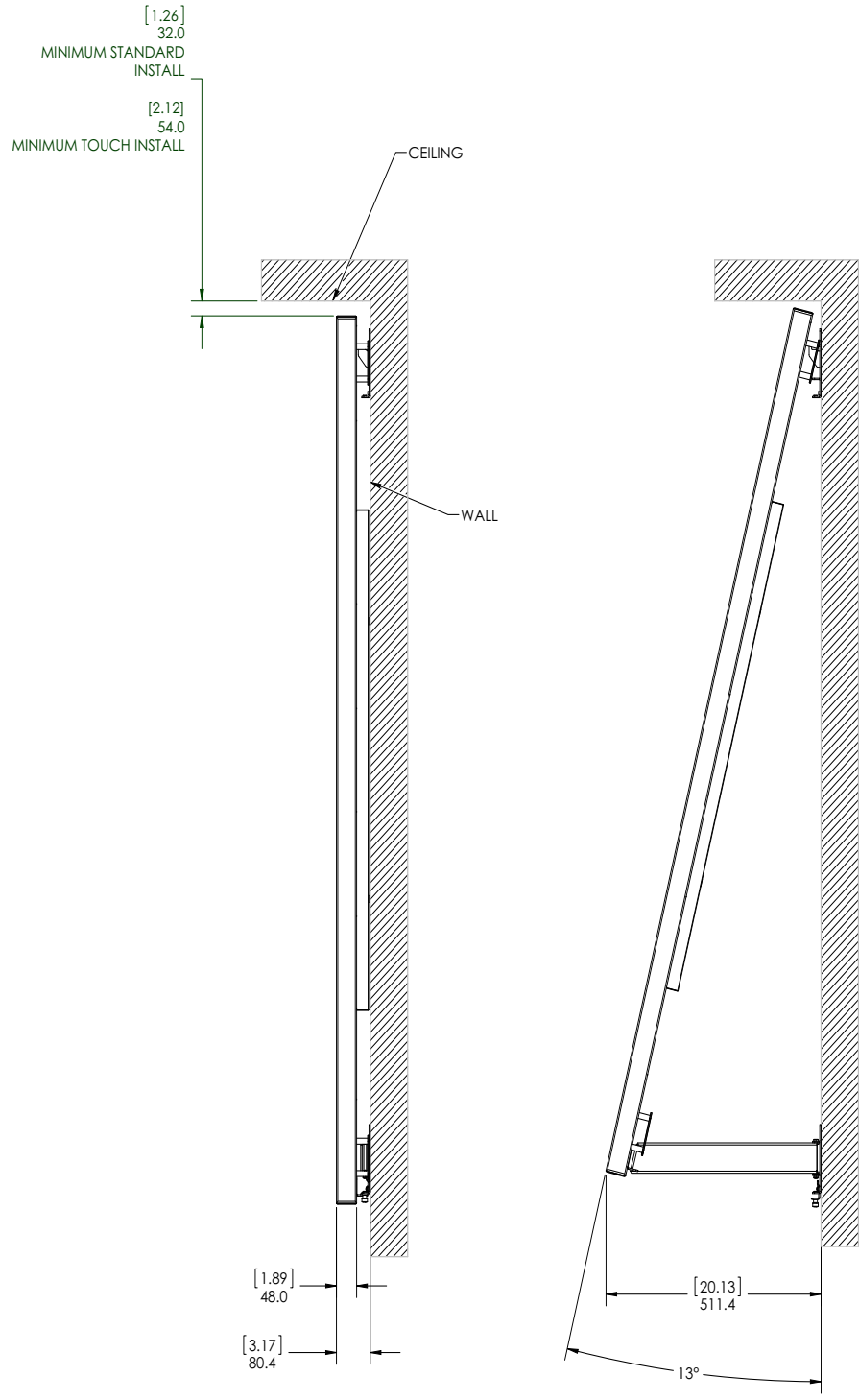

Installed position

Service position - with kickstand supporting display



## 70" Touch Front and Side Views

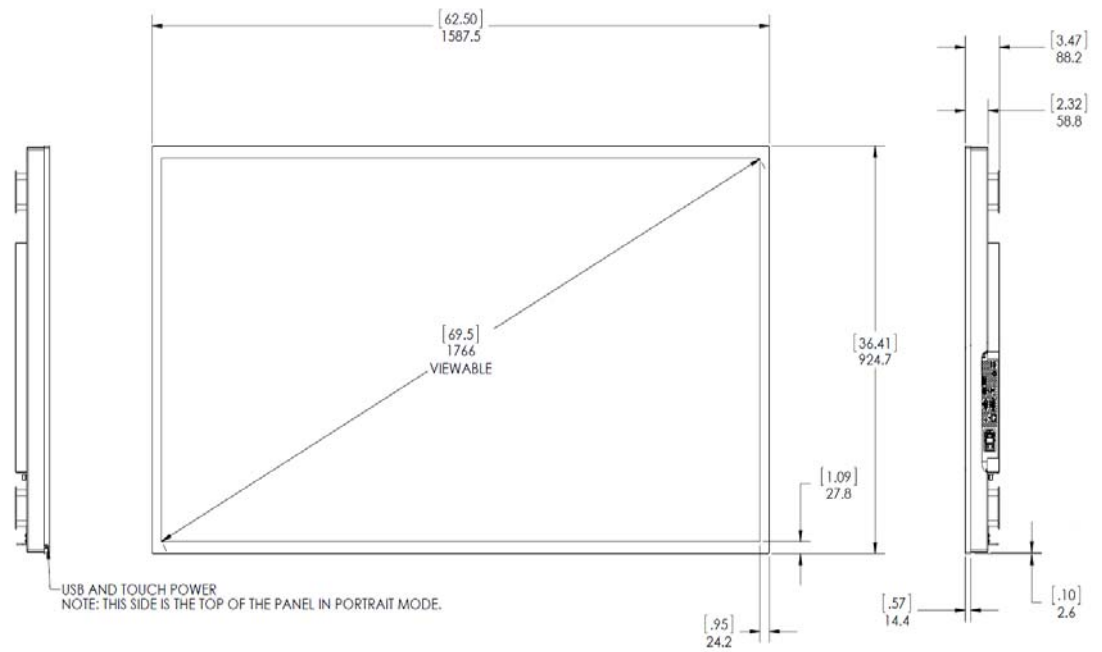

**Note:** All other dimensions are the same as non-touch 70"

# 80" Display Dimensions - Front and Side Views

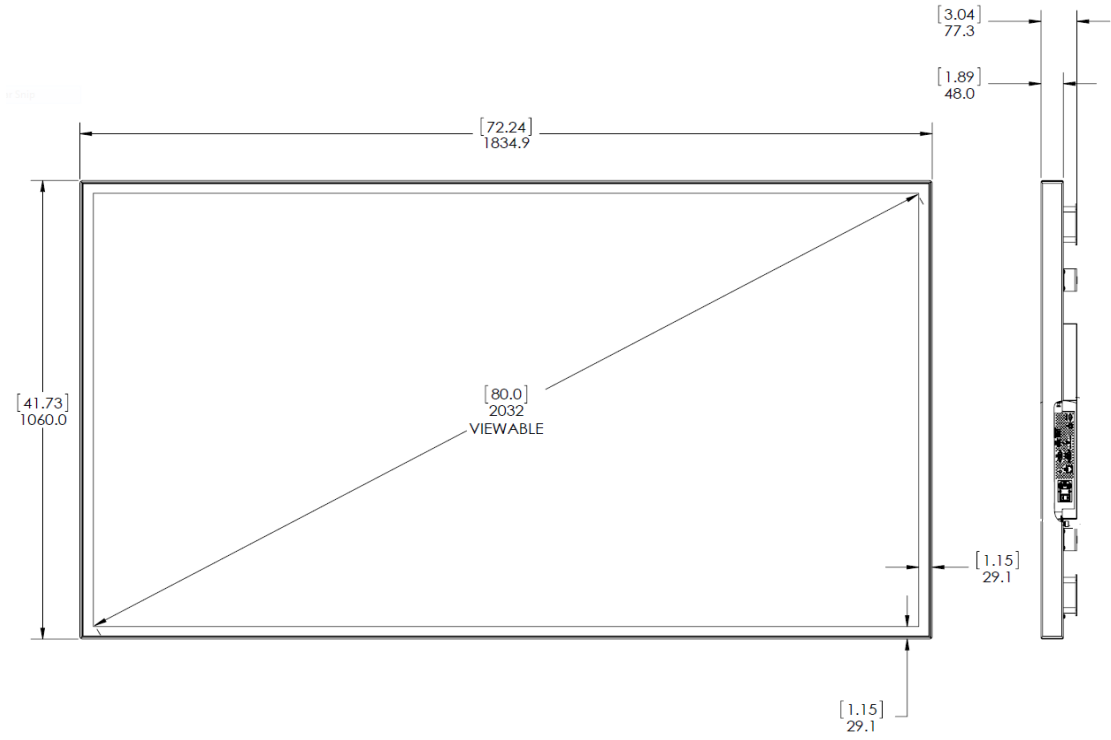

# 80" Display Dimensions - Rear View

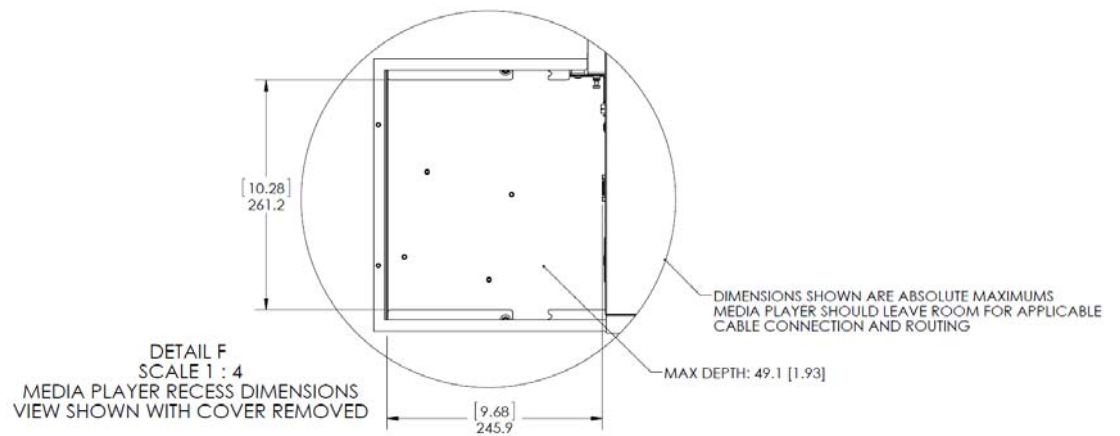
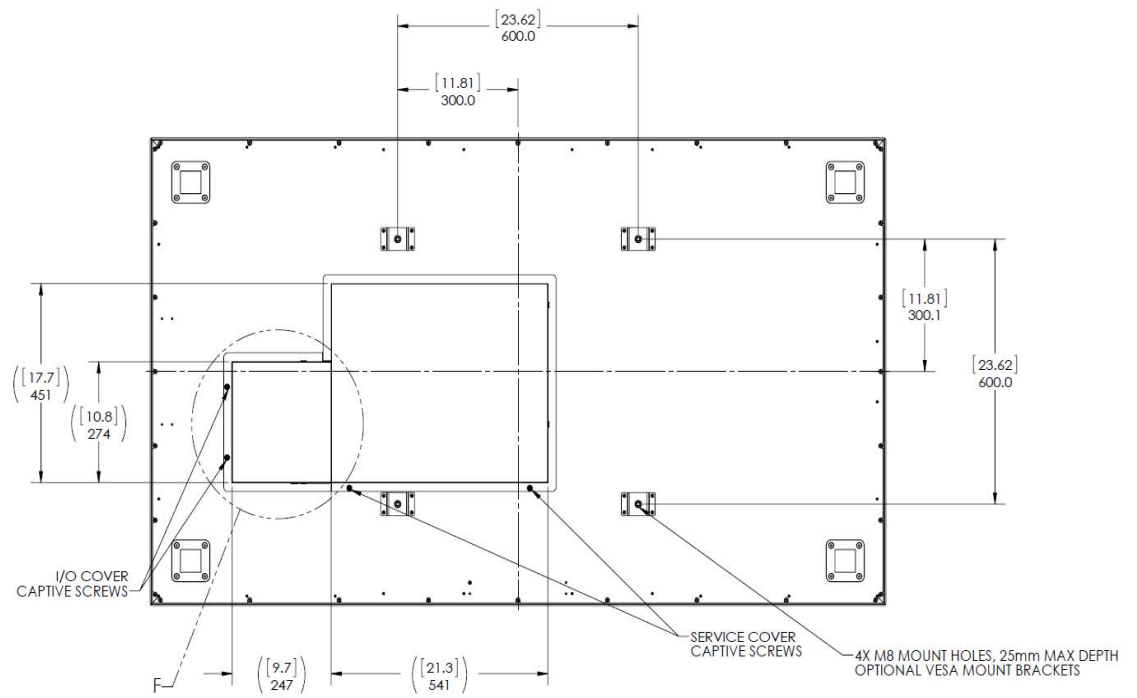

# 80" Rear View - Wall Mount Hangers and Service Panel Locations

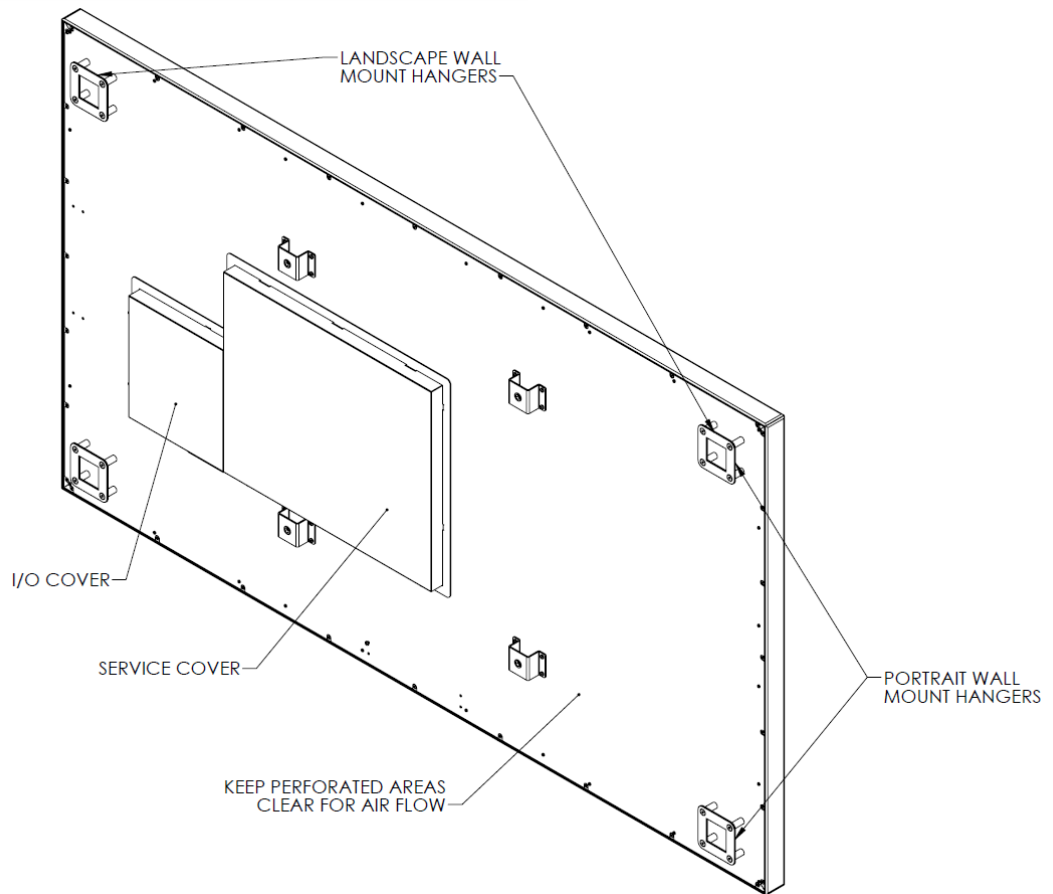

# 80" Landscape Wall Mounts - Front and Bottom Views

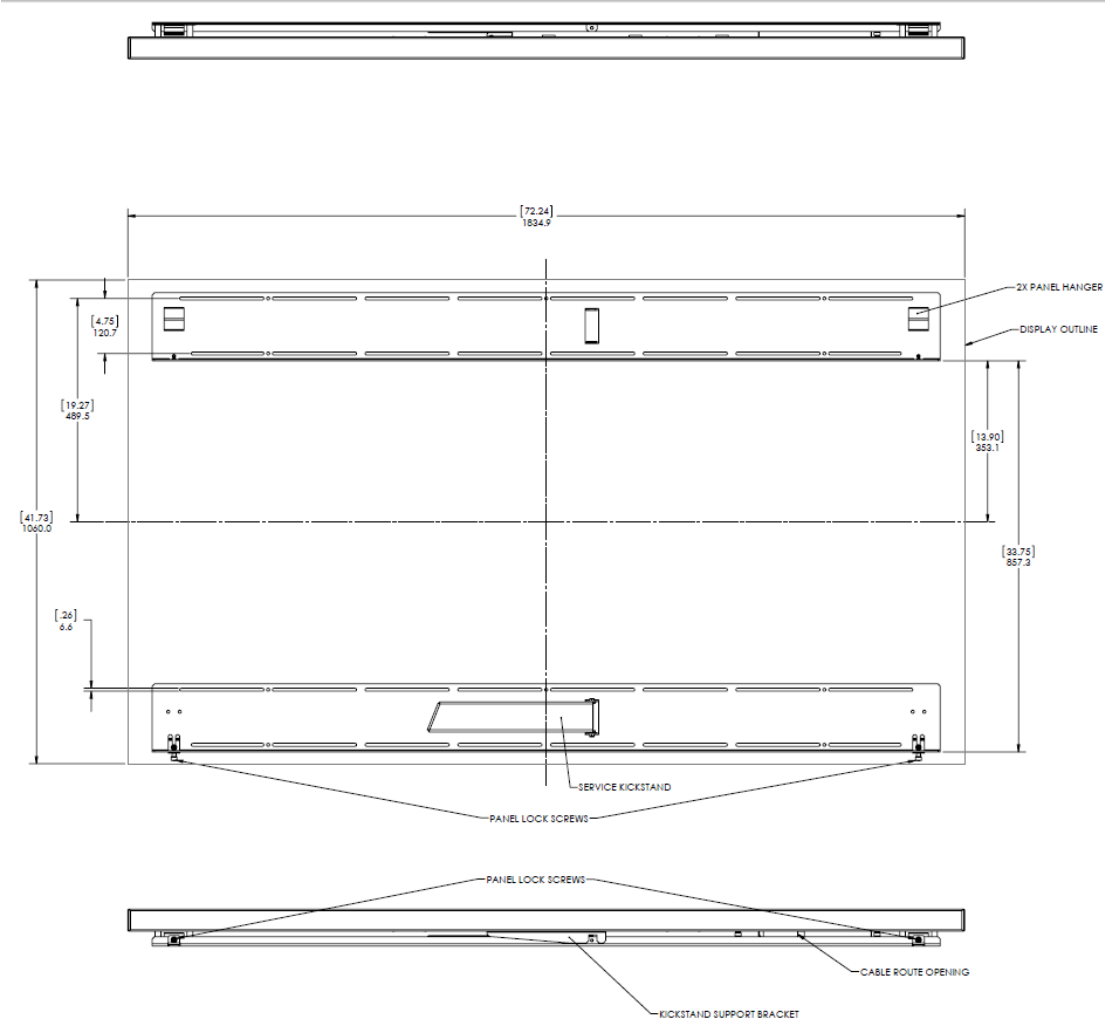

# 80" Landscape Wall Mounts - Side Views

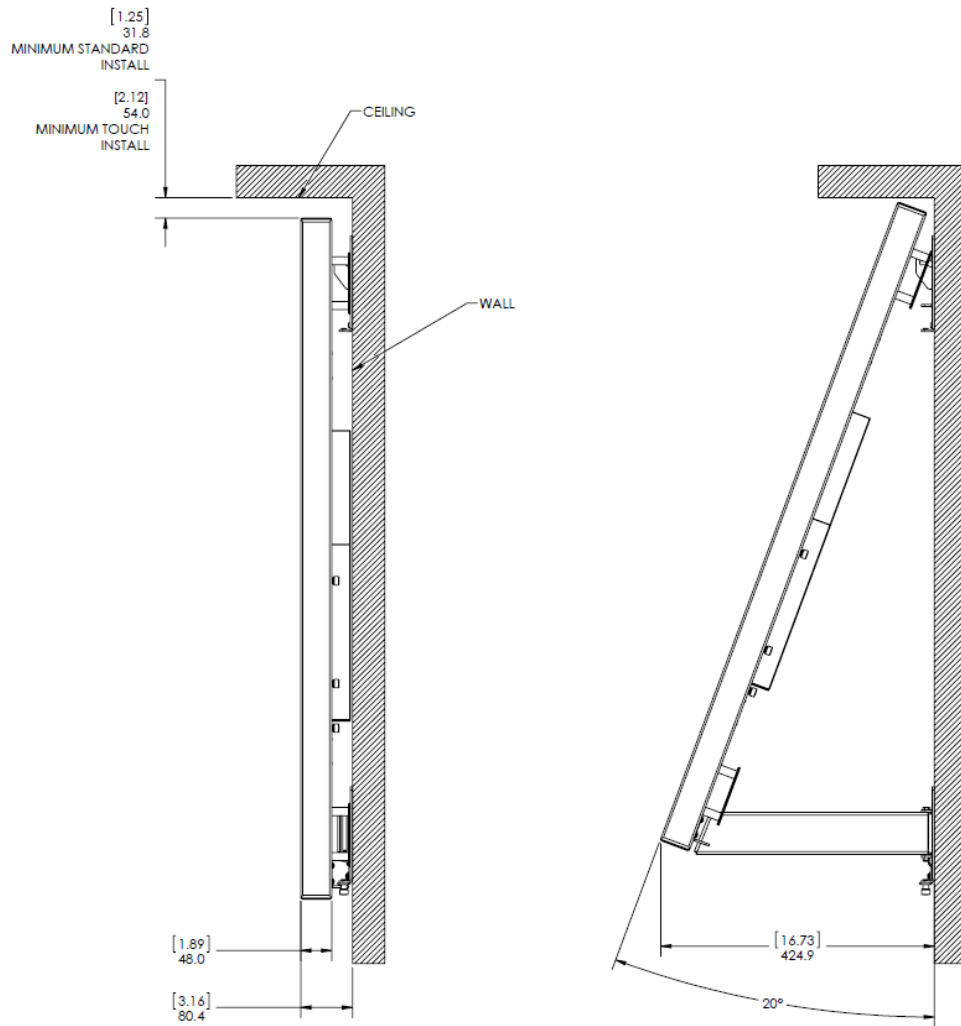

# 80" Portrait Wall Mounts - Front View

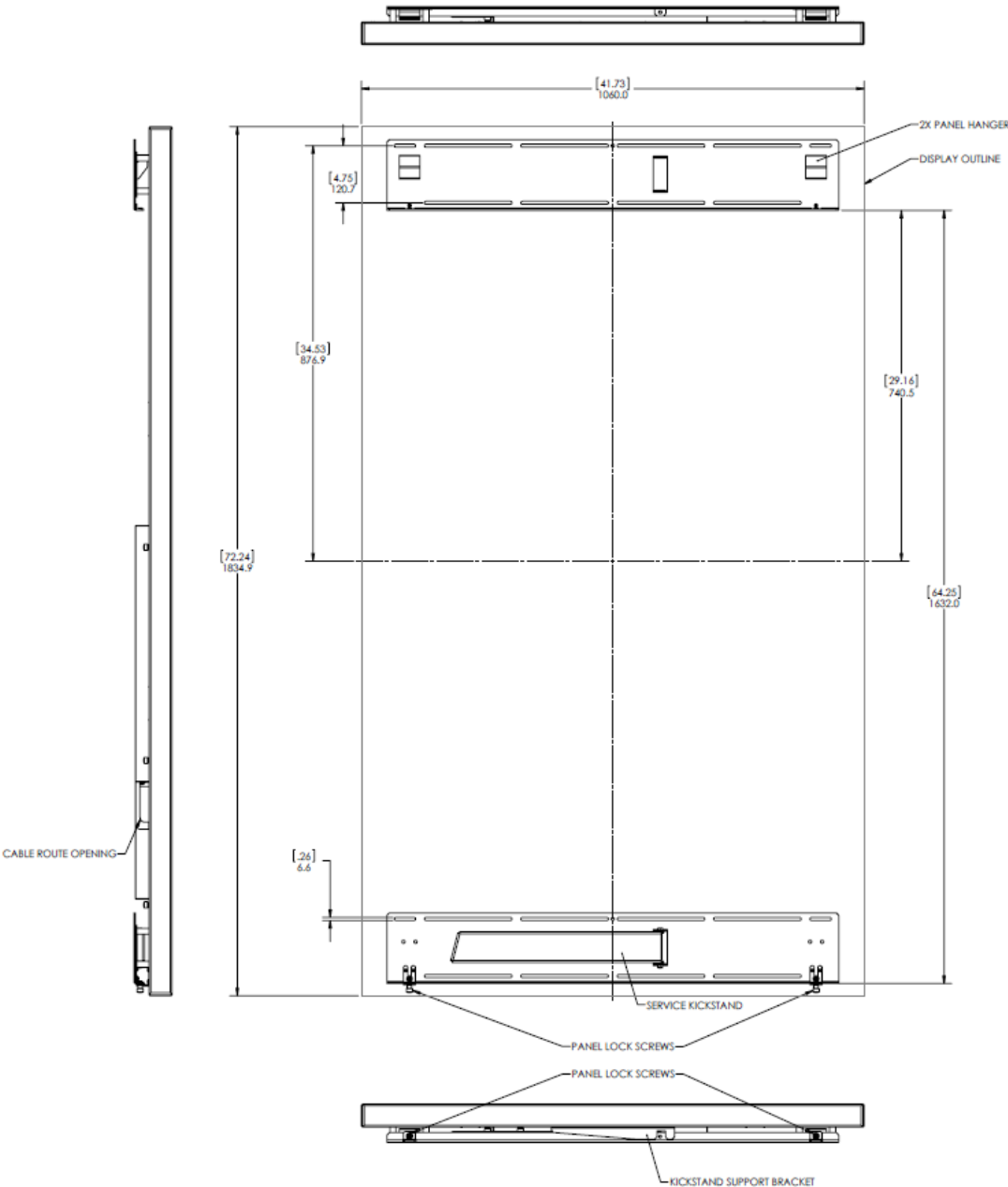

# 80" Portrait Wall Mounts - Side Views

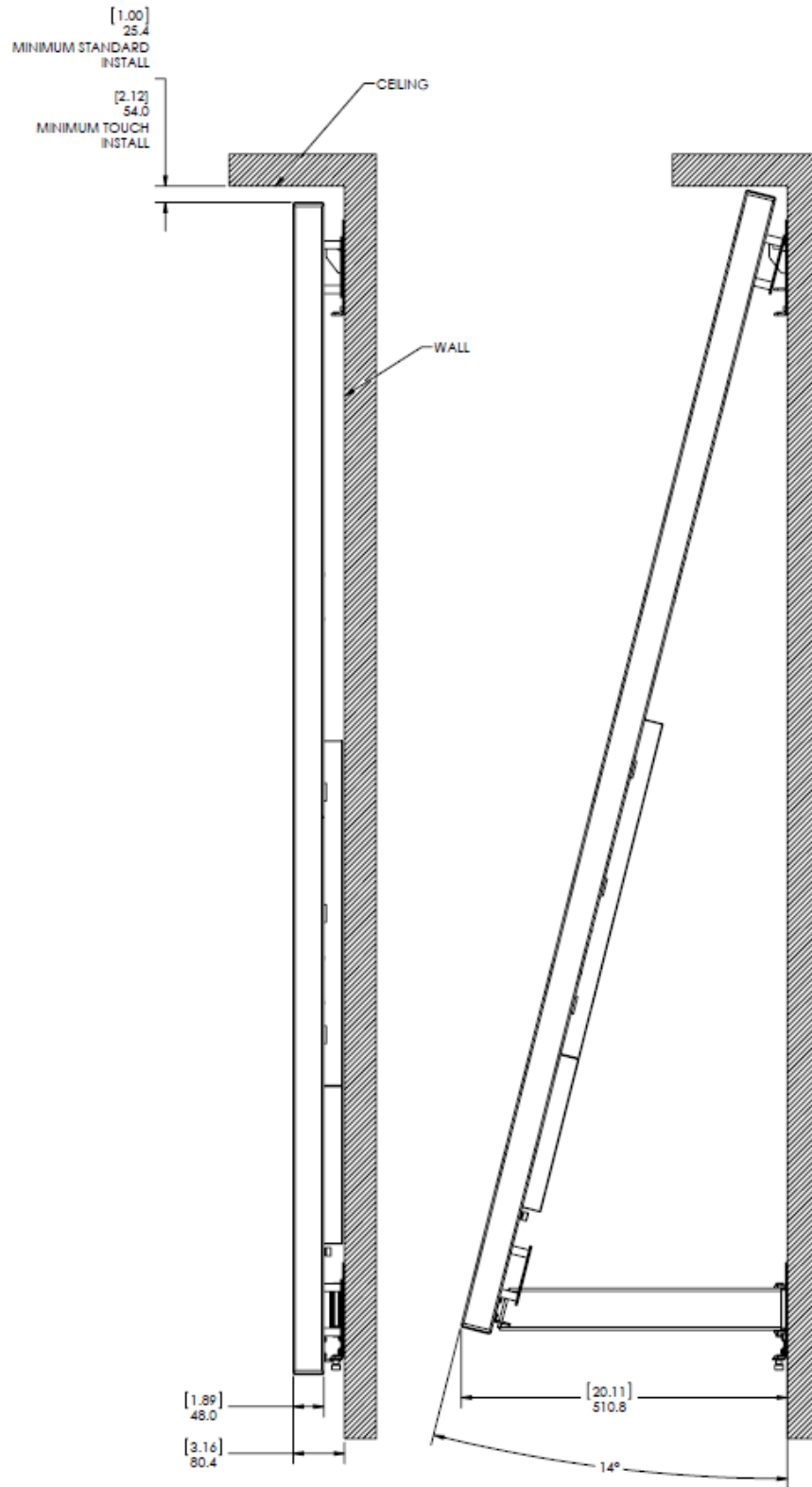



## 80" Touch Front and Side Views

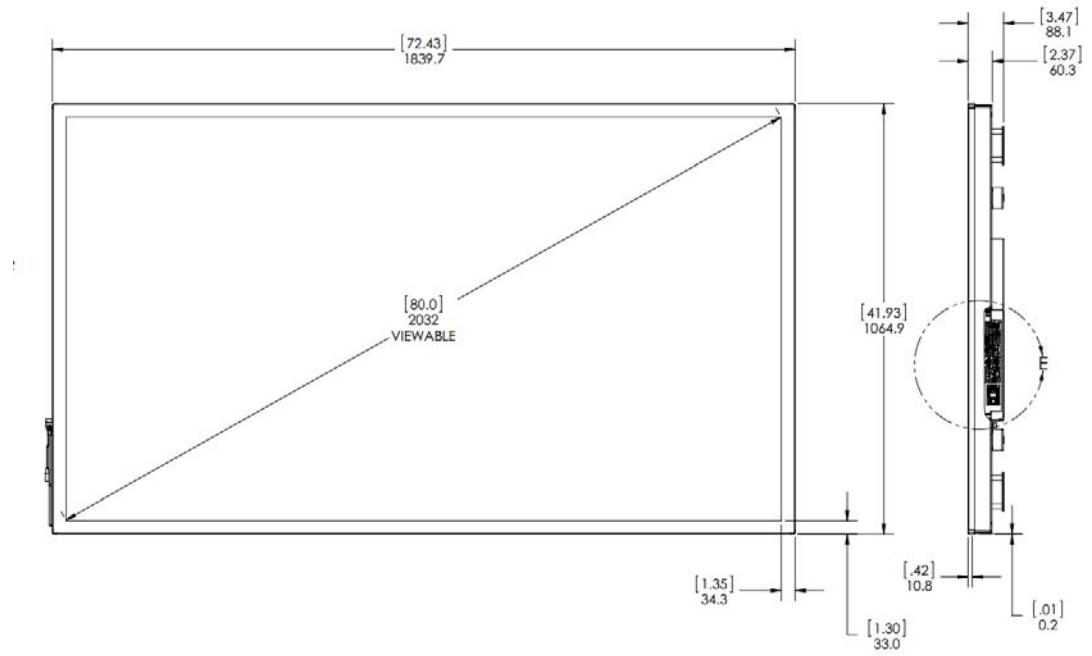

**Note:** All other dimensions are the same as non-touch 80".

# Regulatory Information

Manufacturer's Name: Planar Systems, Inc.  
Manufacturer's Address: 1195 NW Compton Drive  
Beaverton, OR 97006

Declares that the products Model Numbers: Planar UltraLux Series 70"/80" large format LCDs.

Conforms with the provisions of:

Council Directive 2004/108/EC on Electromagnetic Compatibility;

EN55022:2010 Radiated and Conducted Emissions from IT Equipment

EN55024:1998 Immunity of IT Equipment

Including:	EN61000-4-2	Electrostatic Discharge
	EN61000-4-3	Radiated Immunity
	EN61000-4-4	Electrical Fast Transients
	EN61000-4-5	Line Surge
	EN61000-4-6	RF Conducted Susceptibility
	EN61000-4-8	Magnetic Field Immunity
	EN61000-4-11	Voltage Dips and Interrupts

And:	EN61000-3-2	Harmonic Current Emissions
	EN61000-3-3	Voltage fluctuations and Flicker

Council Directive 2006/95/EC on Low Voltage Equipment Safety:

EN60950:2006+A11 Safety of IT Equipment

The Technical Construction File required by this Directive is maintained at the corporate headquarters of Planar Systems, Inc., 1195 NW Compton Drive, Beaverton, OR 97006.

Note: This equipment has been tested and found to comply with the limits for a Class A digital device, pursuant to part 15 of the FCC Rules. These limits are designed to provide reasonable protection against harmful interference when the equipment is operated in a commercial environment. This equipment generates, uses, and can radiate radio frequency energy and, if not installed and used in accordance with the instruction manual, may cause harmful interference to radio communications. Operation of this equipment in a residential area is likely to cause harmful interference in which case the user will be required to correct the interference at his own expense.

Industry Canada (ICES-003): This Class A digital apparatus complies with Canadian ICES-003.

Cet appareil numérique de la classe A est conforme à la norme NMB-003 du Canada.

Any changes or modifications to the display not expressly approved by Planar could void the user's authority to operate this equipment.

Other Certifications

CISPR 22

# Customer Support Information

24/7 Online Technical Support is available at <http://www.planar.com/support>

## Customer Support Contact Information and Hours of Operation

Tel: 1-866-PLANAR1 (866-752-6271) or +1 503-748-1100

Hours: M-F, 8am - 8pm Eastern Time | M-F, 5am - 5pm Pacific Time

## Warranty and Service Plans

Planar warranty and service plans will help you maximize your investment by providing great support, display uptime, and performance optimization. From post-sale technical support to a full suite of depot services, our services are performed by trained Planar employees. When you purchase a Planar product, you get more than a display, you get the service and support you need to maximize your investment. To find the latest warranty and service information regarding your Planar product, please visit: [http://www.planar.com/support/warranty/standard\\_warranties/](http://www.planar.com/support/warranty/standard_warranties/)

### Warranty Features

- 3-year protection from defects in material and workmanship
- Advanced shipment of replacement part or product
- Access to 24x7 emergency phone support
- Please visit: [http://www.planar.com/support/warranty/standard\\_warranties/](http://www.planar.com/support/warranty/standard_warranties/) for a full warranty review

© 2012 Planar Systems, Inc. 8/12 Planar is a registered trademark of Planar Systems, Inc. Other brands and names are the property of their respective owners.

Technical information in this document is subject to change without notice.

# Accessing Planar's Technical Support Website

Go to [www.planar.com/support](http://www.planar.com/support) for warranty information, user manuals, touch drivers, and other support information.

# Index

---

## A

- access control
  - in Remote Monitoring, 54
- accessories
  - accessory box contents, 19
  - checking, 18
  - customer-supplied, 19
  - optional, 19
- admin setup
  - in Remote Monitoring, 50
- avoiding temporary image retention, 14

---

## B

- baud rate, 54
- before you begin
  - installing the LCD, 16
  - tools/equipment list, 16

---

## C

- certifications, 82
- cleaning the display screen, 16
- commands
  - creating custom in Remote Monitoring, 49
- conformity information, 82
- Control, 8
- control module, 8
- controlling display via Remote Monitoring, 47
- custom commands
  - in Remote Monitoring, 49
- customer support
  - hours of operation, 83
  - phone numbers, 83
  - website, 83
- customer-supplied accessories, 19

---

## D

- date
  - changing in Remote Monitoring, 53

- diagram of control board architecture, 10
- dimensions, 66
  - display front and side, 66, 74
  - display rear, 67
- display
  - dimensions
    - front and side, 66, 74
    - rear, 67
- Display menu, 60
- disposal information, 13
- drawings, 66

---

## E

- equipment
  - list, 16
- european union disposal information, 13

---

## F

- features of UltraLux, 7

---

## H

- hours of operation for customer support, 83

---

## I

- installation
  - before you build, 20
  - checklist, 18
  - of display on a wall, 21
  - of LCD, 16, 20
  - planning, 16
  - preparing your location, 17
- introduction, 6

---

## K

- kickstand
  - for servicing, 8

kickstand bracket  
using, 28

---

## L

landscape wall mounts  
front view, 69  
side views, 70  
LCD  
installation, 20  
LED technology, 9

---

## M

manufacturer's address, 82  
media player  
integrated, 9  
menus, 57  
Display menu, 60  
Sound menu, 61  
System menu, 62  
mounting system, 8

---

## N

network access  
controlling in Remote Monitoring, 54  
network setup  
in Remote Monitoring, 51  
normal use thermal guidelines, 15

---

## O

on-screen menus, 57  
optional  
accessories, 19  
using the kickstand bracket, 28

---

## P

Planar UltraLux Remote Monitoring, 45  
Planar UltraLux Series, 6  
planning your installation, 16  
portrait wall mounts  
front view, 71, 72  
power

on/off for remote monitoring, 48  
supply, 9  
turning on/off, 17  
preparing your installation location, 17  
product architecture  
of control module, 10

---

## R

rebooting Remote Monitoring, 56  
recommended usage, 14  
redundant power supply, 9  
regulatory information, 82  
remote control, 10  
Remote Monitoring, 45  
Access Control, 54  
Admin Setup, 50  
Custom Commands Setup, 49  
Date and Time, 53  
Display Control, 47  
Home, 45  
Network Setup, 51  
power on/off, 48  
rebooting the system, 56  
Software Setup, 55  
Unit Status, 46  
RS232  
commands, 35  
control, 9

---

## S

safety  
information, 11  
instructions, 11  
service plans, ii, 83  
setting  
baud rate, 54  
setting up network  
in Remote Monitoring, 51  
setting up software  
in Remote Monitoring, 55  
SNMP monitoring, 9, 39  
Sound menu, 61  
System menu, 62

---

## T

- telephone numbers for customer support, 83
- temperature
  - requirements for normal use, 15
- temporary image retention
  - avoiding, 14
  - definition, 14
- thermal guidelines, 15
- time
  - changing in Remote Monitoring, 53
- TIR *see temporary image retention*
- tools/equipment list, 16

---

## U

- UltraLux display
  - installing on a wall, 21
- UltraLux Series
  - features, 7
  - integrated media player, 9
  - LED technology, 9
  - mounting system, 8
  - product architecture, 10
  - remote control, 10
- unit status
  - for Remote Monitoring, 46
- unpacking accessories, 18
- usage information, 14
- using the kickstand bracket, 28

---

## W

- wall mount brackets, 8
- wall mounts
  - landscape front view, 69
  - landscape side views, 70
  - portrait front view, 71, 72
- warranty information, ii, 83
- web access
  - controlling in Remote Monitoring, 54