



Highest Level of Protection for Mission-Critical Information

The Clarity® Matrix™ LCD Video Wall System has added to its mission-critical capabilities with the Fiber Video Extension Option. The Clarity® Matrix™ Fiber Video Extension option provides a more secure and longer distance option for extending the video signal from the off-board Clarity Matrix electronics to the Clarity Matrix LCD video wall displays.

For government and military customers who require fiber optic cabling in their applications, the Fiber Video Extension option for Clarity Matrix is the most mission-critical video wall solution that provides integrated video extension over standard multi-mode or single mode fiber optic cable. Unlike competitive solutions, the Clarity Matrix Fiber Video Extension option is completely integrated into the product, eliminating the need for third-party extension devices or adapters.

MISSION-CRITICAL RELIABILITY

Clarity Matrix is the ultimate LCD video wall solution for the most mission-critical applications. Planar's unique design approach optimizes the thinnest bezel LCD in the industry for 24x7 operation. Its off-board electronics and power supply architecture reduces total-cost-of-ownership while delivering the most reliable LCD video wall.

DESIGNED TO PROTECT SENSITIVE INFORMATION

The Clarity Matrix Fiber Video Extension is designed to be used with optical fiber cabling, the most secure cabling option. Because it neither emits nor receives electromagnetic energy, it is nearly impossible to hack into or eaves drop on highly classified information.

ENGINEERED FOR 24X7 RELIABILITY BEYOND 500 FEET

The unique off-board electronics design of Clarity Matrix provides flexibility in locating the off-board electronics. While typical installations occur within 500 feet of the video wall, that is not always possible. With the Fiber Video Extension, customers have the option to install off-board electronics beyond 500 feet – up to 10km away from the actual video wall.

STREAMLINED CLARITY MATRIX MULTITOUCH INTEGRATION

The Clarity Matrix Fiber Video Extension incorporates an embedded USB extension in the fiber optic cable, eliminating the need for a third party USB extension when using Clarity® Matrix™ MultiTouch interactive LCD video wall displays and other USB devices at the video wall. The LCD modules can also provide power for Clarity Matrix MultiTouch, eliminating the need for separate AC power connection at the video wall.

Fiber Video Extension Module

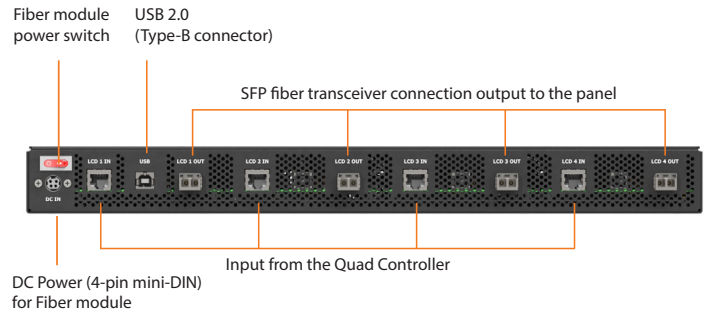

Panel Interface Board

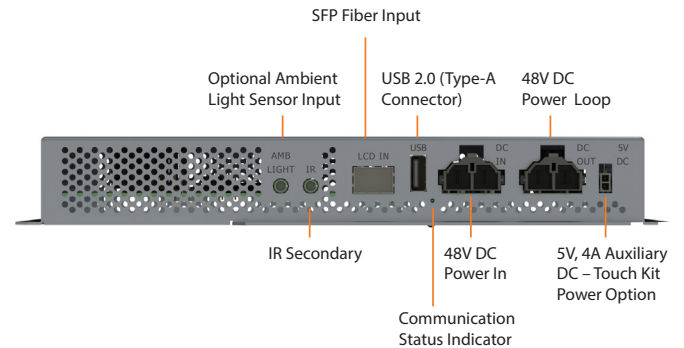

FIBER VIDEO EXTENSION MODULE OPTION

Type	1 U rack mount module drives up to 4 panels.
Fiber Optic Connection Type	SFP multi-mode transceivers supports distances up to 1000 ft (300m) from video wall. Compatible with single-mode transceivers supporting up to 10k from the wall. (Single-mode transceivers not provided)
USB Extension	USB-B @sp module USB-A @sp panel
IR Remote Extension:	Embedded
Power Consumption (typ)	50W
Power Supply	AC Power Adapter
Power Supply Voltage	100-240V AC ± 10%, 47 to 63 Hz

**MULTI-MODE
1000 FT (300M)**

**SINGLE MODE
10K**

MULTI-MODE BULK CABLES AND CONNECTORS AVAILABLE TO SUPPORT FIELD TERMINATED LENGTHS



www.planar.com
sales@planar.com
1-866-475-2627

Leyard and Planar are trademarks of Leyard Optoelectronics Co., Ltd. and Planar Systems, Inc. All other trademarks and service marks are the property of their holders.

Copyright© 2016 Leyard Optoelectronics Co., Ltd. and Planar Systems, Inc. All rights reserved. This document may not be copied in any form without permission from Leyard or Planar. Information in this document is subject to change without notice. 3/16